

A photograph of a modern architectural courtyard. The central focus is a tall, narrow glass tower with a grid pattern, rising from a courtyard. The courtyard is flanked by large, multi-story concrete buildings with a textured facade. The ground is paved with large, light-colored tiles. The sky is blue with some clouds. The overall aesthetic is clean, minimalist, and architectural.

Catálogo
Catalogue

M PROJECT

BATHROOM ESSENTIALS



M PROJECT

Creemos que una casa puede ser mucho más que un espacio.

Un lugar que se adapta a ti.
Donde todo encaja.
Donde cada detalle importa.

M Project diseña y fabrica grifería y accesorios para el baño con este objetivo. Piezas donde el diseño, la innovación y la calidad se unen para hacer más cómodos, más fluidos y agradables nuestros espacios.

We believe a home can be much more than a space.

A place that adapts to you.
Where everything fits.
Where every detail matters.

At **M Project**, we design and manufacture bathroom taps and accessories with this purpose. To create pieces where design, innovation and quality come together to make our spaces more comfortable, more fluid and more enjoyable.

Acabados que se adaptan a tu estilo

Finishes that adapt to your style

Cada proyecto tiene su propio lenguaje. M Project propone una gama de acabados que permite personalizar y crear composiciones únicas. Materiales y tonalidades que dialogan con la arquitectura y refuerzan la identidad del espacio.

Every project has its own language. M Project offers a range of finishes, enabling you to personalize spaces and create unique compositions. Materials and tones designed to work in harmony with the architecture and reinforce the identity of the space.



CR

Cromo
Chrome



INOX

Acero inoxidable
Stainless steel



NG

Negro mate
Matt black



GCP

Grafito cepillado PVD
Brushed gun metal PVD



OCP

Oro cepillado PVD
Brushed gold PVD



CCP

Cobre cepillado PVD
Brushed copper PVD



MCP

Marrón café cepillado PVD
Brushed coffee brown PVD

^{5P}
Metrik

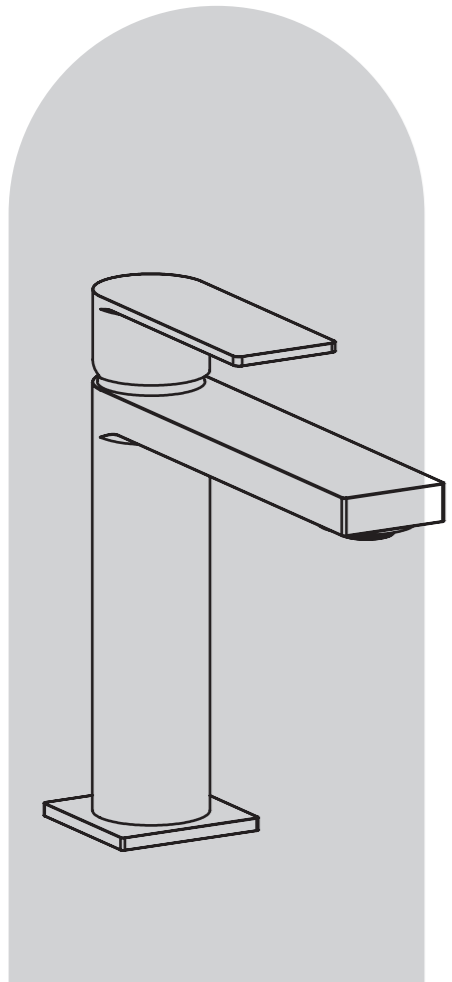

7

^{3P}
Tube

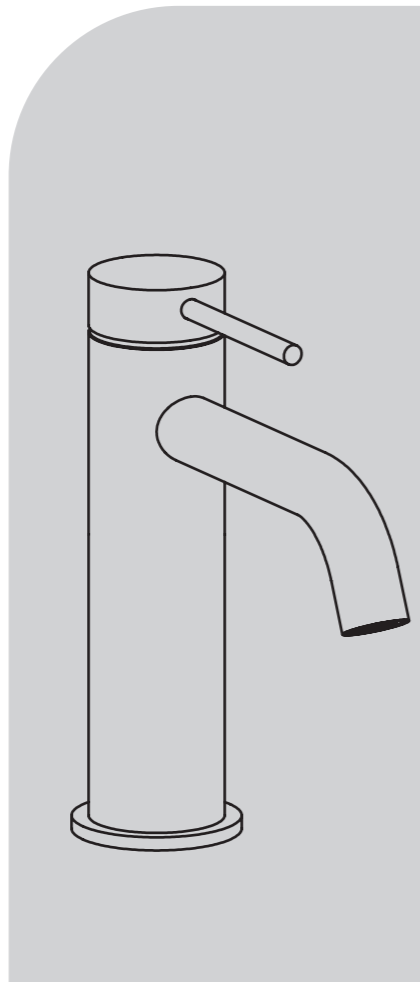

36

^{2P}
Neo

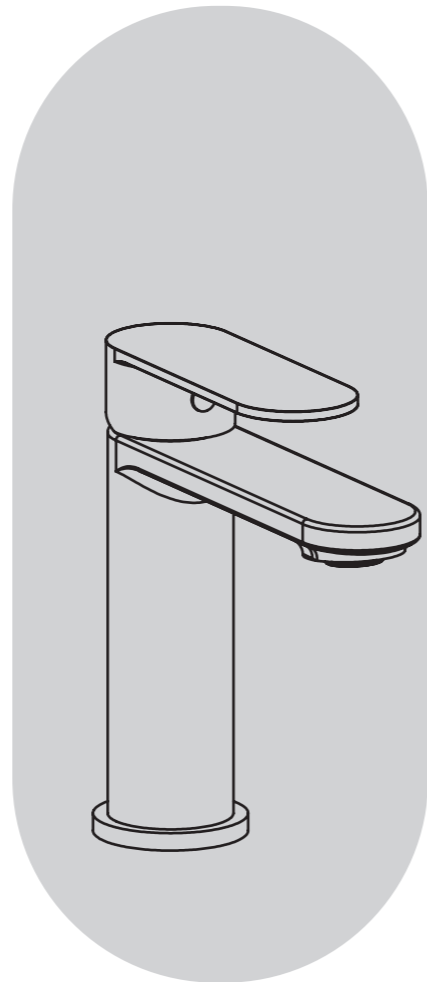

62

^{3P}
Kitchen

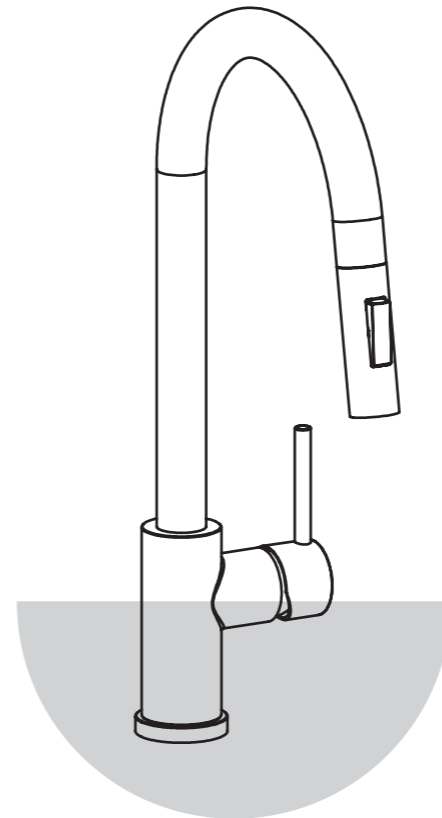

92

^{6H}
Hydrotherapy

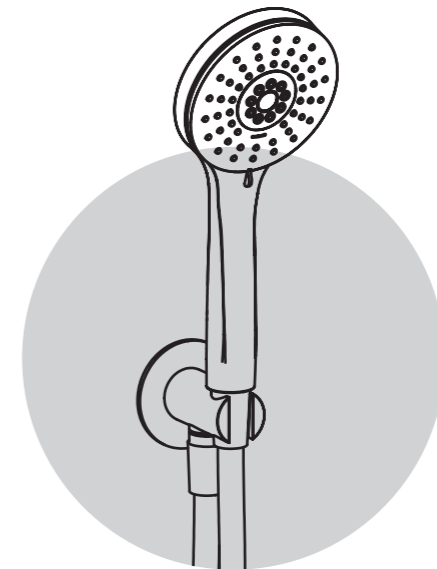

102

^{3A}
Accessories

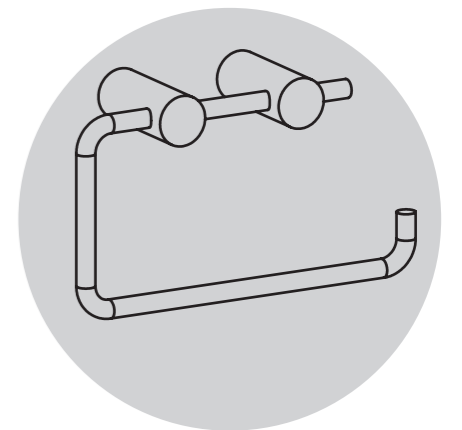

126



5P Metrik

La calma de la geometría
The calm of geometry

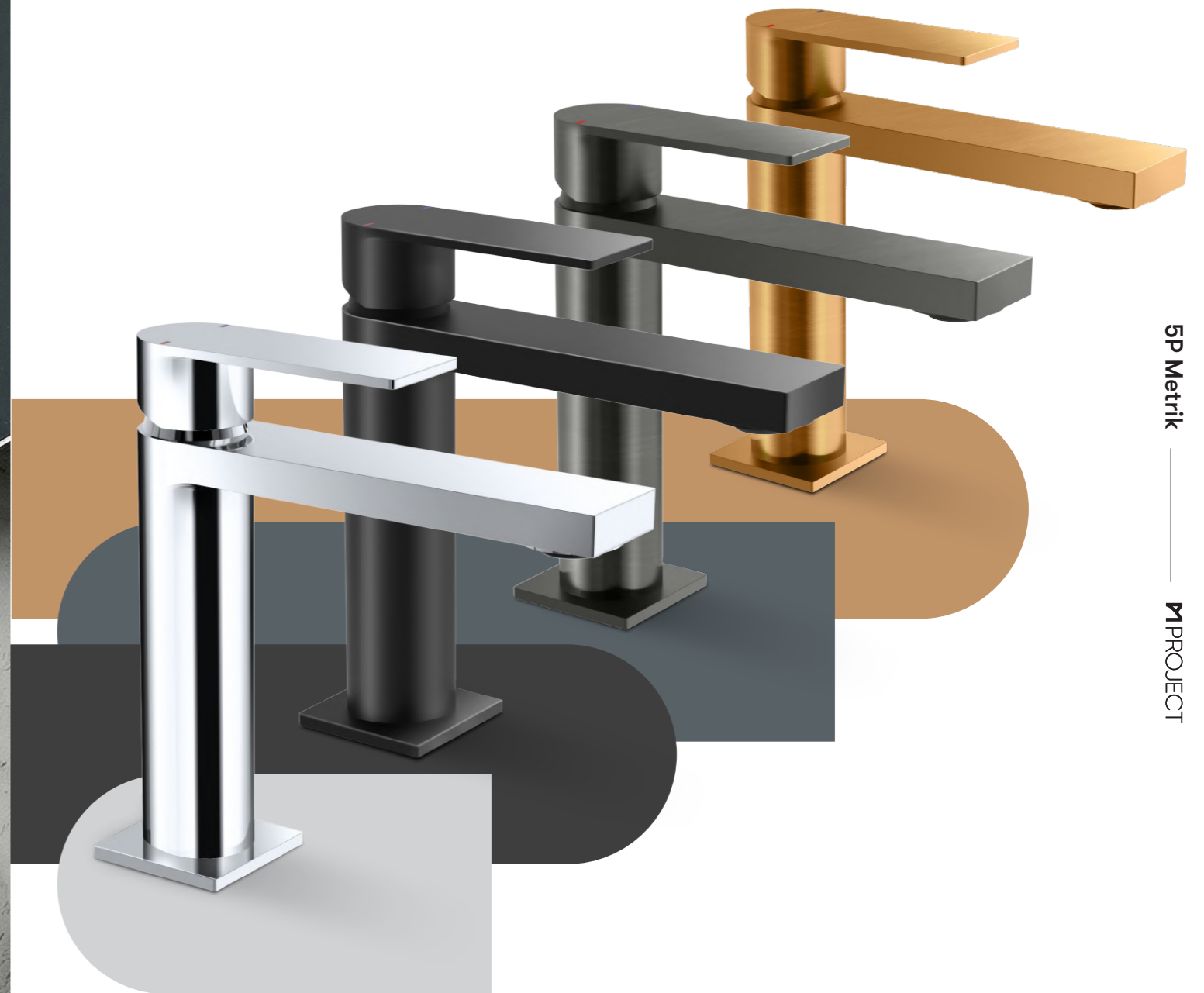

Diseño racional Rational design

METRIK se define por líneas rectas y proporciones exactas. Una propuesta sin gestos superfluos, donde la forma se expresa desde la claridad con una estética moderna y decidida. Pensada para espacios contemporáneos que entienden el orden, la estructura y coherencia visual como parte del lenguaje arquitectónico.

METRIK is defined by straight lines and exact proportions. A proposal without superfluous gestures, where form is expressed through clarity and a modern, confident aesthetic. Designed for contemporary spaces that understand order, structure and visual coherence as part of architectural language.

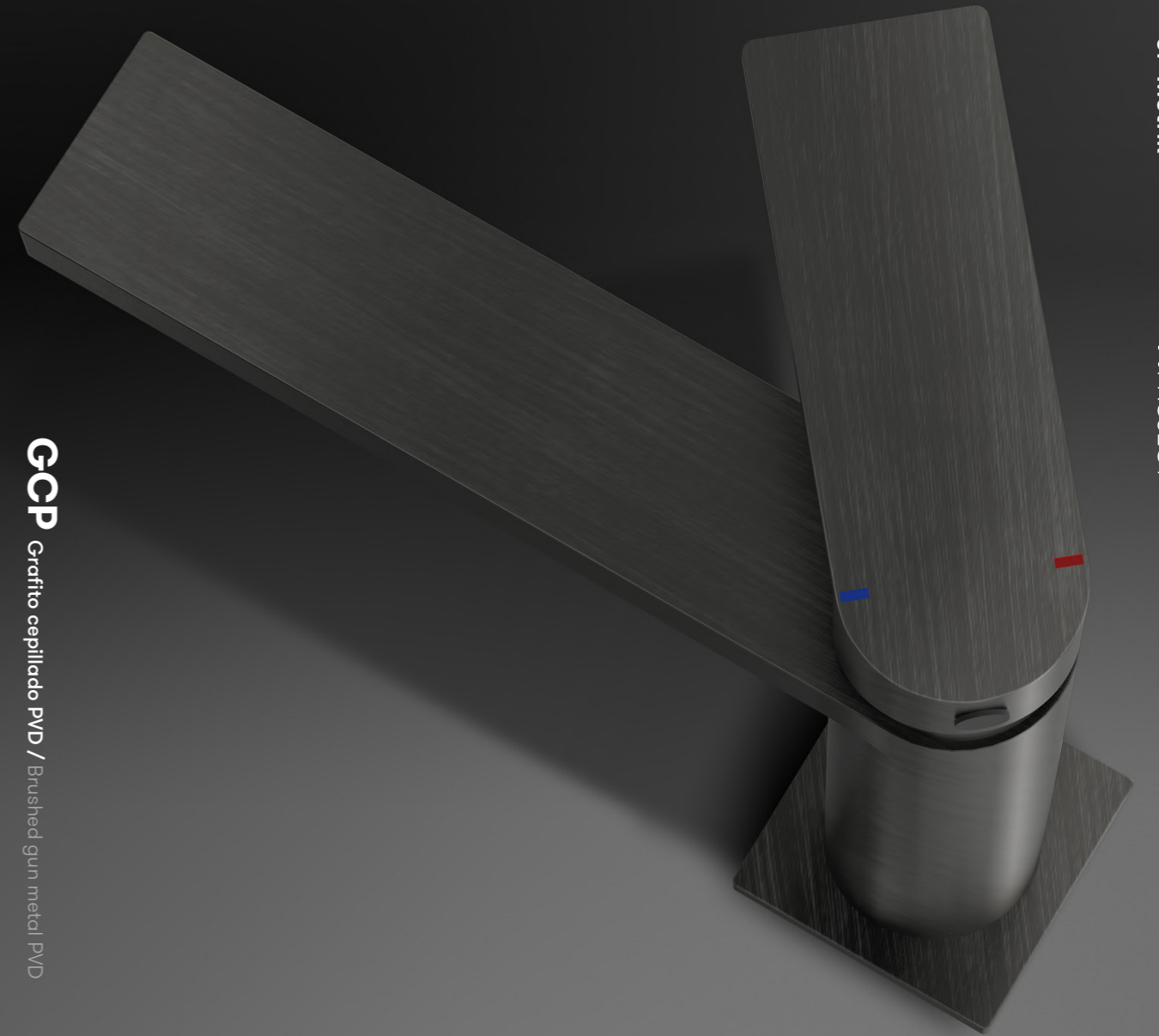

5P Metrik ——— MPROJECT

GCP Grafito cepillado PVD / Brushed gun metal PVD

5P 002

Monomando lavabo
Wash-basin mixer

NG Negro mate / Matt black



5P 102

Monomando lavabo alto
High wash-basin mixer

OCP Oro cepillado PVD / Brushed gold PVD



5P Metrik ——— MPROJECT



CR
Cromo / Chrome

5P Metrik ——— MPROJECT

5P 302

Monomando lavabo empotrado
Built-in single-lever wash-basin mixer



NG Negro mate / Matt black

5P 312

Monomando empotrar baño ducha
Built-in bath shower mixer

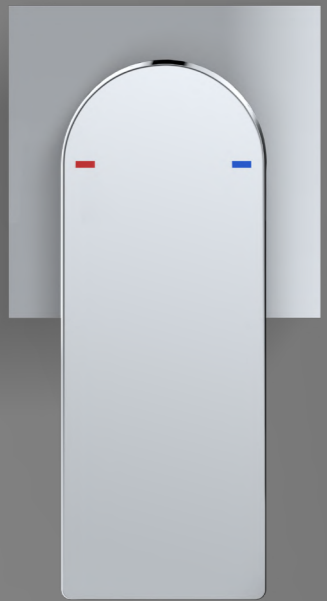

CR Cromo / Chrome

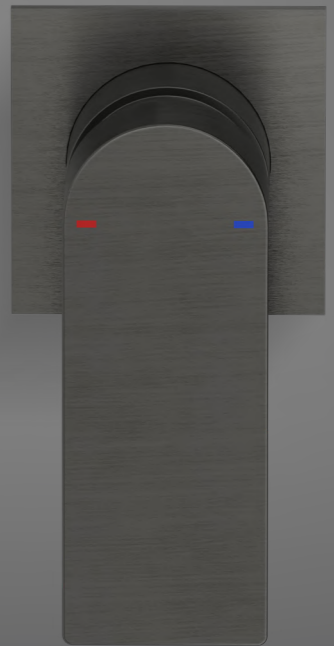

GCP Grafito cepillado PVD / Brushed gun metal PVD

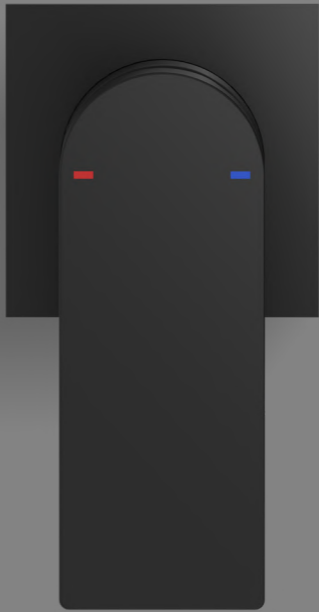

NG Negro mate / Matt black

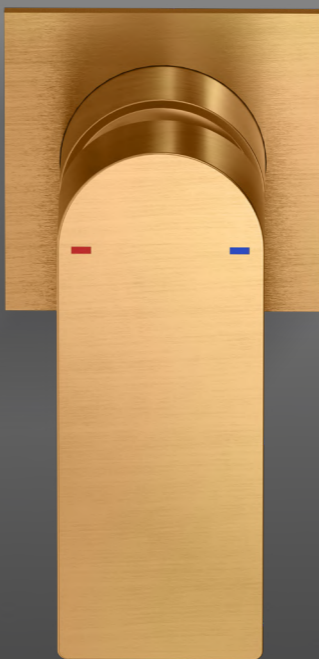

OCP Oro cepillado PVD / Brushed gold PVD

5P 315

Monomando empotrar ducha
Built-in shower mixer



GCP Grafito Cepillado PVD / Brushed gun metal PVD

5P 012

Monomando baño ducha con accesorios
Bath and shower mixer with accessories



OCP Oro cepillado PVD / Brushed gold PVD

5P Metrik ——— MPROJECT

5P 015

Monomando ducha con accesorios
Shower mixer with accessories



OCP
Oro cepillado PVD / Brushed gold PVD



NG
Negro mate / Matt black

5P 322 / 5P 323

Conjunto monomando ducha empotrado 2/3 vías con toma con soporte, ducha y flexo 1,70 m
Concealed shower set with shower mixer, diverter 2/3 ways, wall outlet with support, handshower and flexible hose 1,70 m



CR Cromo / Chrome



5P Metrik ——— MPROJECT

5P 413 S300

Columna ducha cilíndrica telescópica con grifo monomando, ducha de mano, flexo 1,70 m y rociador 300 mm redondo

Cylindrical telescopic shower column with single-lever mixer, hand shower, 1,70 m flexible hose and round 300 mm showerhead

5P Metrik

Acabados disponibles
Available finishes



CR

Cromo
Chrome
Chrome
Хром

NG

Negro mate
Matt black
Noir mate
Черное



OCP

Oro cepillado PVD
Brushed gold PVD
Or brossé PVD
Брашированное золото PVD

GCP

Grafito Cepillado PVD
Brushed gun metal PVD
Graphite brossé PVD
Матовый металл PVD

5P Metrik



Lavabo
Washbasin



5P 002

Monomando lavabo
Wash-basin mixer
Mitigeur lavabo
Однорычажный Смеситель для раковины

5P 004

Monomando lavabo válv. desag. click-clack
Wash-basin mixer with click-clack waste
Mitigeur lavabo avec vidage click-clack
Однорычажный смеситель для раковины с донным клапаном клик-клак

5P 102

Monomando lavabo alto
High wash-basin mixer
Mitigeur lavabo haut
Однорычажный Смеситель для раковин высокий

5P 104

Monomando lavabo alto válv. desag. click-clack
High wash-basin mixer with click-clack waste
Mitigeur lavabo haut avec vidage click-clack
Однорычажный смеситель для раковины высокий с клапаном клик-клак

Lavabo
Washbasin



5P 302

Monomando lavabo empotrado, partes externas
Built-in single-lever wash-basin mixer, external parts
Mitigeur lavabo mural à encastrer, partie externe
Встраиваемый однорычажный смеситель для раковины внешняя часть

5P 304

Monomando lavabo empotrado con válv. click-clack, partes externas
Built-in single-lever wash-basin mixer with click-clack waste, external parts
Mitigeur lavabo mural à encastrer avec vidage click-clack, partie externe
Встраиваемый однорычажный смеситель для раковины с клапаном клик-клак внешняя часть

Requiere cuerpo interno **MBOX302** (no incluido)
Requires inner body **MBOX302** (not included)

MBOX302

Cuerpo interno universal con caja de instalación para monomando lavabo empotrado
Universal inner body with installation box for built-in single-lever wash-basin mixer
Corps d'encastrement universel avec boîtier d'installation pour mitigeur lavabo à encastrer
Универсальная внутренняя часть со встраиваемой коробкой для встроенного однорычажного смесителя для раковины

5P Metrik



Bidé
Bidet



5P 009

Monomando bidé
Bidet mixer
Mitigeur bidet
Однорычажный смеситель для биде

5P 011

Monomando bidé válv. desag. click-clack
Bidet mixer with click-clack waste
Mitigeur bidet avec vidage click-clack
Однорычажный смеситель для биде с клапаном клик-клак

Baño ducha
Bath tub



5P 012

Monomando baño ducha con accesorios
Bath and shower mixer with accessories
Mitigeur bain-douche avec accessoires
Смеситель для ванны и душа с держателем ручного душа

Ducha
Shower



5P 015

Monomando ducha con accesorios
Shower mixer with accessories
Mitigeur douche avec ensemble de douche
Смеситель для душа с держателем ручного душа

5P Metrik



Baño ducha
Bath tub



5P 312

Monomando baño ducha empotrado, partes externas
Built-in bath shower mixer, external parts
Mitigeur bain-douche à encastrer, partie externe
Встроенный смеситель для ванны и душа внешняя часть

Requiere cuerpo interno **MBOX312** (no incluido)
Requires inner body **MBOX312** (not included)

MBOX312

Cuerpo interno universal con caja de instalación para monomando baño ducha empotrado
Universal inner body with installation box for built-in single-lever bath shower mixer
Corps d'encastrement universel avec boîtier d'installation pour mitigeur bain-douche à encastrer
Универсальная внутренняя часть со встраиваемой коробкой для встроенного однорычажного смесителя для раковины

Ducha
Shower

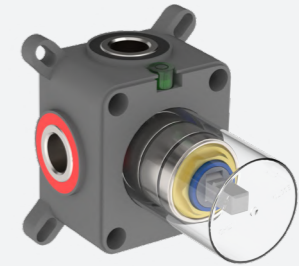

5P 315

Monomando ducha empotrado, partes externas
Built-in shower mixer, external parts
Mitigeur douche à encastrer, partie externe
Встроенный смеситель для душа внешняя часть

Requiere cuerpo interno **MBOX315** (no incluido)
Requires inner body **MBOX315** (not included)

MBOX315

Cuerpo interno universal con caja de instalación para monomando ducha empotrado
Universal inner body with installation box for built-in single-lever shower mixer
Corps d'encastrement universel avec boîtier d'installation pour mitigeur douche à encastrer
Универсальная внутренняя часть со встраиваемой коробкой для встроенного однорычажного смесителя для раковины

5P Metrik



Baño ducha
Bathroom

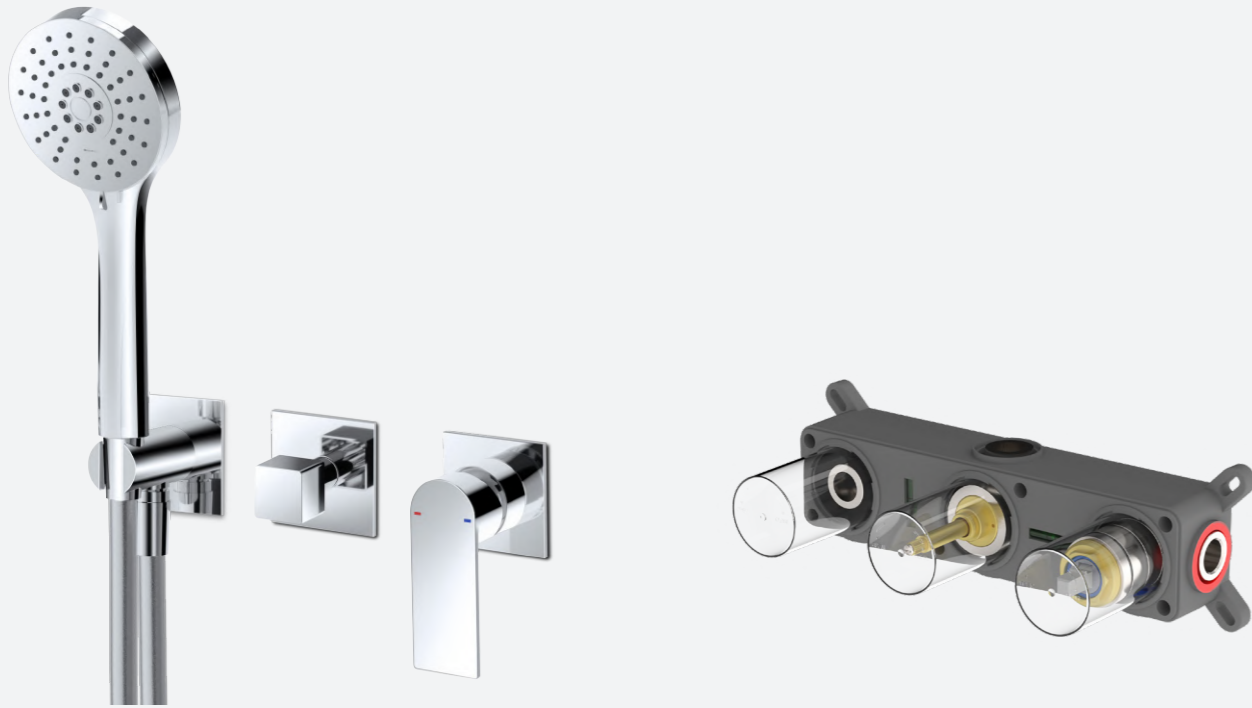

5P 322 / 5P 323

Conjunto monomando ducha empotrado 2/3 vías con toma con soporte, ducha y flexo 1,70 m, partes externas
Concealed shower set with shower mixer, diverter 2/3 ways, wall outlet with support, handshower and flexible hose 1,70 m, external parts
Ensemble mitigeur de douche 2/3 voies avec coude mural et support, douche et flexible de 1,70 m, partie externe
Встроенный душевой гарнитур со смесителем для душа, переключателем на 2/3 выхода, настенным выпуском с держателем ручного душа и гибким шлангом 1,70 м

Requiere cuerpo interno **MBOX322/MBOX323** (no incluido)
Requires inner body **MBOX322/MBOX323** (not included)

MBOX322

Cuerpo interno universal con caja de instalación para conjunto monomando ducha empotrado 2 vías
Universal inner body with installation box for 2-way built-in single-lever shower mixer
Corps d'encastrement universel avec boîtier d'installation pour mitigeur douche à encastrer 2 voies
Универсальная внутренняя часть со встраиваемой коробкой для встроенного однорычажного смесителя для душа на 2 потока

MBOX323

Cuerpo interno universal con caja de instalación para conjunto monomando ducha empotrado 3 vías
Universal inner body with installation box for 3-way built-in single-lever shower mixer
Corps d'encastrement universel avec boîtier d'installation pour mitigeur douche à encastrer 3 voies
Универсальная внутренняя часть со встраиваемой коробкой для встроенного однорычажного смесителя для душа на 3 потока

Baño ducha
Bathroom



5P 312 S300

Conjunto monomando baño ducha empotrado con toma con soporte, ducha de mano y flexo 1,70 m con brazo de ducha pared y rociador 300 mm redondo, partes externas
Built-in single-lever bath/shower mixer with wall outlet with support, hand shower and 1,70 m flexible hose, round 300 mm showerhead and wall arm, external parts
Mitigeur bain-douche à encastrer avec support douchette avec alimentation, flexible 1,70 m et pomme de douche de 300 mm avec bras de douche rond, partie externe
Встроенный однорычажный смеситель для ванны/душа, с подводом воды и держателем, ручным душем, гибким шлангом 1,70 м, с крыгой верхней лейкой 300 мм, с держателем из стены, внешние части

Requiere cuerpo interno **MBOX312** (no incluido)
Requires inner body **MBOX312** (not included)



5P 322 S300 / 5P 323 S300

Conjunto monomando ducha empotrado con inversor 2/3 vías, toma con soporte, ducha de mano y flexo 1,70 m, brazo de ducha pared y rociador 300 mm redondo, partes externas
Built-in single-lever shower mixer with diverter 2/3 ways, wall outlet with support, hand shower and 1,70 m flexible hose, round 300 mm showerhead and wall arm, external parts
Ensemble mitigeur douche à encastrer avec inverseur 2/3 voies, avec support douchette et alimentation, flexible 1,70 m et pomme de douche 300 mm avec bras de douche rond, partie externe
Встроенный однорычажный смеситель для душа с переключателем на 2/3 потока с подводом воды, ручным душем, гибким шлангом 1,70 м, с крыгой верхней лейкой 300 мм, с держателем из стены, внешние части

Requiere cuerpo interno **MBOX322/MBOX323** (no incluido)
Requires inner body **MBOX322/MBOX323** (not included)

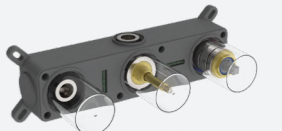

5P Metrik



Columna ducha
Shower column



5P 413 S300

Columna ducha cilíndrica telescópica con grifo monomando, ducha de mano, flexo 1,70 m y rociador 300 mm redondo
Cylindrical telescopic shower column with single-lever mixer, hand shower, 1,70 m flexible hose and round 300 mm showerhead
Ensemble mitigeur avec colonne de douche cylindrique télescopique, douchette et flexible de 1,70 m et pomme de douche 300 mm
Цилиндрическая телескопическая душевая стойка с однорычажным смесителем, ручной лейкой, гибким шлангом 1,70 м и верхней лейкой 300 мм

Ducha de mano
Hand shower



5P 130

Toma de agua con soporte, ducha de mano 3 funciones ABS y flexo 1,70 m
Water outlet with support, 3-function hand shower ABS and flexible hose 1,70 m
Support avec alimentation, douchette ABS 3 fonctions et flexible 1,70 m
Держатель с подводом воды, с ручным душем из ABS, с 3-мя переключателями воды, с гибким шлангом 1,70 м





3P Tube

La forma de lo esencial
The shape of the essential



Una forma. Distintas expresiones. One shape. Different expressions.

TUBE parte de un gesto único. Una forma pura, continua, reconocible, que se convierte en el eje de toda la colección. A partir de ahí, el color transforma la experiencia. Una colección pensada para quienes entienden el diseño como equilibrio entre sencillez, carácter y elección personal.

TUBE is born from a single gesture. A pure, continuous and recognizable form that becomes the backbone of the entire collection. From there, colour transforms the experience. A collection conceived for those who understand design as a balance between simplicity, character and personal choice.

OCP
Oro cepillado PVD /
Brushed gold PVD



GCP
Grafito cepillado PVD /
Brushed gun metal PVD



CR
Cromo / Chrome



CCP
Cobre cepillado PVD /
Brushed copper PVD



INOX
Acero inoxidable /
Stainless steel



MCP
Marrón café cepillado PVD /
Brushed coffee brown PVD



NG
Negro mate / Matt black

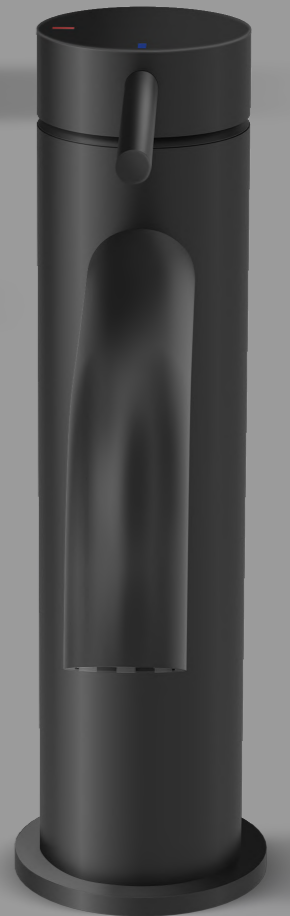

3P 002

Monomando lavabo
Wash-basin mixer



CCP Cobre cepillado PVD / Brushed copper PVD



CR Cromo / Chrome

3P Tube ——— MPROJECT

3P 102

Monomando lavabo alto
High wash-abasin mixer



MCP Marrón café cepillado PVD / Brushed coffee brown PVD

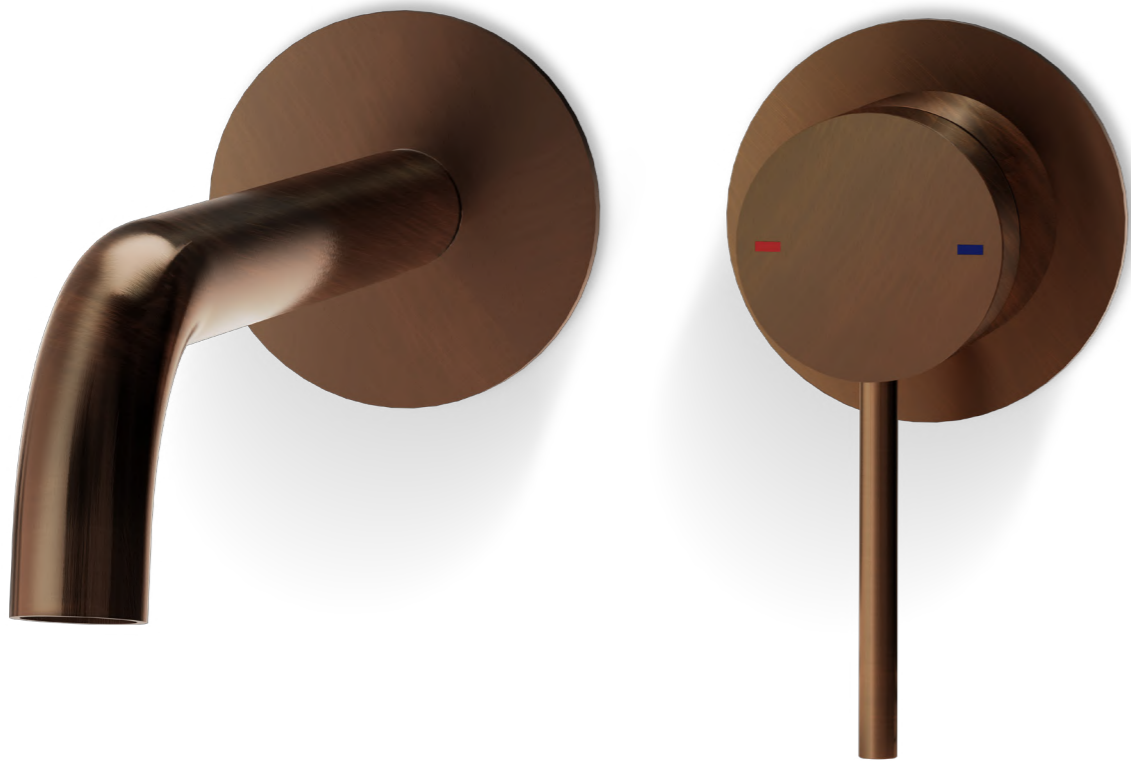

3P 302

Monomando lavabo empotrado
Built-in single-lever wash-basin mixer

3P Tube ——— MPROJECT

OCP Oro cepillado PVD / Brushed gold PVD





OCP Oro cepillado PVD / Brushed gold PVD

3P 312

Monomando empotrar baño ducha
Built-in bath shower mixer



GCP Grafito cepillado PVD /
Brushed gun metal PVD



CCP Cobre cepillado PVD /
Brushed cooper PVD



MCP Marrón café cepillado PVD /
Brushed coffee brown PVD

3P 315

Monomando empotrar ducha
Built-in shower mixer



OCP Oro cepillado PVD / Brushed gold PVD



NG Negro mate / Matt black



CR Cromo / Chrome



INOX Acero inoxidable / Stainless steel



INOX
Acero inoxidable / Stainless steel

3P 322 / 3P 323

Conjunto monomando ducha empotrado 2/3 vías con toma con soporte, ducha y flexo 1,70 m, partes externas
Concealed shower set with shower mixer, diverter 2/3 ways, wall outlet with support, handshower and flexible hose 1,70 m, external parts





NG Negro mate / Matt black

3P 413 S300

Columna ducha cilíndrica telescópica con grifo monomando, ducha de mano, flexo 1,70 m y rociador 300 mm redondo
Cylindrical telescopic shower column with single-lever mixer, hand shower, 1,70 m flexible hose and round 300 mm showerhead



GCP Grafito cepillado PVD / Brushed gun metal PVD

3P 415 S300

Columna ducha cilíndrica telescópica con grifo termostático, ducha de mano, flexo 1,70 m y rociador 300 mm redondo
Cylindrical telescopic shower column with thermostatic mixer, hand shower, 1,70 m flexible hose and round 300 mm showerhead



GCP Cobre cepillado PVD / Brushed copper PVD

3P Tube

Acabados disponibles
Available finishes



INOX

Acero Inoxidable
Stainless Steel
Acier Inoxydable
Нержавеющая сталь

CR

Cromo
Chrome
Chrome
Хром

NG

Negro mate
Matt black
Noir mate
Черное



OCP

Oro cepillado PVD
Brushed gold PVD
Or brossé PVD
Брашированное
золото PVD

GCP

Grafito Cepillado PVD
Brushed gun metal PVD
Graphite brossé PVD
матовый металл PVD

CCP

Cobre cepillado PVD
Brushed copper PVD
Cuivre brossé PVD
Матовая медь PVD

MCP

Marrón café cepillado PVD
Brushed coffee brown PVD
Marron café brossé PVD
Матовый кофейно-коричневый PVD

3P Tube



Lavabo
Washbasin



3P 002

Monomando lavabo
Wash-basin mixer
Mitigeur lavabo
Однорычажный смеситель для раковины

3P 004

Monomando lavabo válv. desag. click-clack
Wash-basin mixer with click-clack waste
Mitigeur lavabo avec vidage click-clack
Однорычажный смеситель для раковины с донным клапаном клик-клак

3P 102

Monomando lavabo alto
High wash-basin mixer
Mitigeur lavabo haut
Однорычажный смеситель для раковин высокий

3P 104

Monomando lavabo alto válv. desag. click-clack
High wash-basin mixer with click-clack waste
Mitigeur lavabo haut avec vidage click-clack
Однорычажный смеситель для раковины высокий с клапаном клик-клак

Lavabo
Washbasin



3P 302

Monomando lavabo empotrado, partes externas
Built-in single-lever wash-basin mixer, external parts
Mitigeur lavabo mural à encastrer, partie externe
Встраиваемый однорычажный смеситель для раковины внешняя часть

3P 304

Monomando lavabo empotrado con válv. click-clack, partes externas
Built-in single-lever wash-basin mixer with click-clack waste, external parts
Mitigeur lavabo mural à encastrer avec vidage click-clack, partie externe
Встраиваемый однорычажный смеситель для раковины с клапаном клик-клак внешняя часть

Requiere cuerpo interno **MBOX302** (no incluido)
Requires inner body **MBOX302** (not included)

MBOX302

Cuerpo interno universal con caja de instalación para monomando lavabo empotrado
Universal inner body with installation box for built-in single-lever wash-basin mixer
Corps d'encastrement universel avec boîtier d'installation pour mitigeur lavabo à encastrer
Универсальная внутренняя часть со встраиваемой коробкой для встроенного однорычажного смесителя для раковины

3P Tube



Baño ducha
Bath tub



3P 312

Monomando baño ducha empotrado, partes externas
Built-in bath shower mixer, external parts
Mitigeur bain-douche à encastrer, partie externe
Встроенный смеситель для ванны и душа внешняя часть

Requiere cuerpo interno **MBOX312** (no incluido)
Requires inner body **MBOX312** (not included)

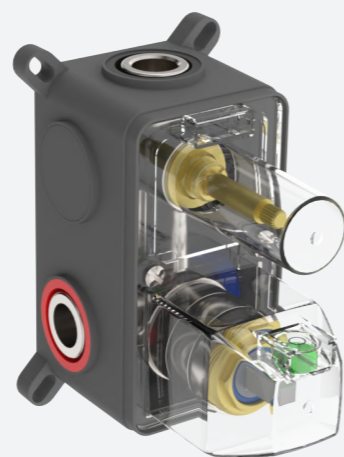

MBOX312

Cuerpo interno universal con caja de instalación para monomando baño ducha empotrado
Universal inner body with installation box for built-in single-lever bath shower mixer
Corps d'encastrement universel avec boîtier d'installation pour mitigeur bain-douche à encastrer
Универсальная внутренняя часть со встраиваемой коробкой для встроенного однорычажного смесителя для раковины

Ducha
Shower



3P 315

Monomando ducha empotrado, partes externas
Built-in shower mixer, external parts
Mitigeur douche à encastrer, partie externe
Встроенный смеситель для душа внешняя часть

Requiere cuerpo interno **MBOX315** (no incluido)
Requires inner body **MBOX315** (not included)



MBOX315

Cuerpo interno universal con caja de instalación para monomando ducha empotrado
Universal inner body with installation box for built-in single-lever shower mixer
Corps d'encastrement universel avec boîtier d'installation pour mitigeur douche à encastrer
Универсальная внутренняя часть со встраиваемой коробкой для встроенного однорычажного смесителя для раковины

3P Tube



Baño ducha
Bath tub



3P 322 / 3P 323

Conjunto monomando ducha empotrado 2/3 vías con toma con soporte, ducha y flexo 1,70 m, partes externas
Concealed shower set with shower mixer, diverter 2/3 ways, wall outlet with support, handshower and flexible hose 1,70 m, external parts
Ensemble mitigeur de douche 2/3 voies avec coude mural et support, douche et flexible de 1,70 m, partie externe
Встроенный душевой гарнитур со смесителем для душа, переключателем на 2/3 выхода, настенным выпуском с держателем ручного душа и гибким шлангом 1,70 м

Requiere cuerpo interno **MBOX322/MBOX323** (no incluido)
Requires inner body **MBOX322/MBOX323** (not included)

MBOX322

Cuerpo interno universal con caja de instalación para conjunto monomando ducha empotrado 2 vías
Universal inner body with installation box for 2-way built-in single-lever shower mixer
Corps d'encastrement universel avec boîtier d'installation pour mitigeur douche à encastrer 2 voies
Универсальная внутренняя часть со встраиваемой коробкой для встроенного однорычажного смесителя для душа на 2 потока

MBOX323

Cuerpo interno universal con caja de instalación para conjunto monomando ducha empotrado 3 vías
Universal inner body with installation box for 3-way built-in single-lever shower mixer
Corps d'encastrement universel avec boîtier d'installation pour mitigeur douche à encastrer 3 voies
Универсальная внутренняя часть со встраиваемой коробкой для встроенного однорычажного смесителя для душа на 3 потока

Baño ducha
Bath tub



3P 312 S300

Conjunto monomando baño ducha empotrado con toma con soporte, ducha de mano y flexo 1,70 m con brazo de ducha pared y rociador 300 mm redondo, partes externas
Built-in single-lever bath/shower mixer with wall outlet with support, hand shower and 1,70 m flexible hose, round 300 mm showerhead and wall arm, external parts
Mitigeur bain-douche à encastrer avec support douchette avec alimentation, flexible 1,70 m et pomme de douche de 300 mm avec bras de douche rond, partie externe
Встроенный однорычажный смеситель для ванны/душа, с подводом воды и держателем, ручным душем, гибким шлангом 1,70 м, с крыгой верхней лейкой 300 мм, с держателем из стены, внешние части

Requiere cuerpo interno **MBOX312** (no incluido)
Requires inner body **MBOX312** (not included)



3P 322 S300 / 3P 323 S300

Conjunto monomando ducha empotrado con inversor 2/3 vías, toma con soporte, ducha de mano y flexo 1,70 m, brazo de ducha pared y rociador 300 mm redondo, partes externas
Built-in single-lever shower mixer with diverter 2/3 ways, wall outlet with support, hand shower and 1,70 m flexible hose, round 300 mm showerhead and wall arm, external parts
Ensemble mitigeur douche à encastrer avec inverseur 2/3 voies, avec support douchette et alimentation, flexible 1,70 m et pomme de douche 300 mm avec bras de douche rond, partie externe
Встроенный однорычажный смеситель для душа с переключателем на 2/3 потока с подводом воды, ручным душем, гибким шлангом 1,70 м, с крыглым верхним душем 300 мм, с держателем из стены, внешние части

Requiere cuerpo interno **MBOX322/MBOX323** (no incluido)
Requires inner body **MBOX322/MBOX323** (not included)

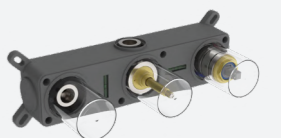

3P Tube



Columna ducha
Shower column

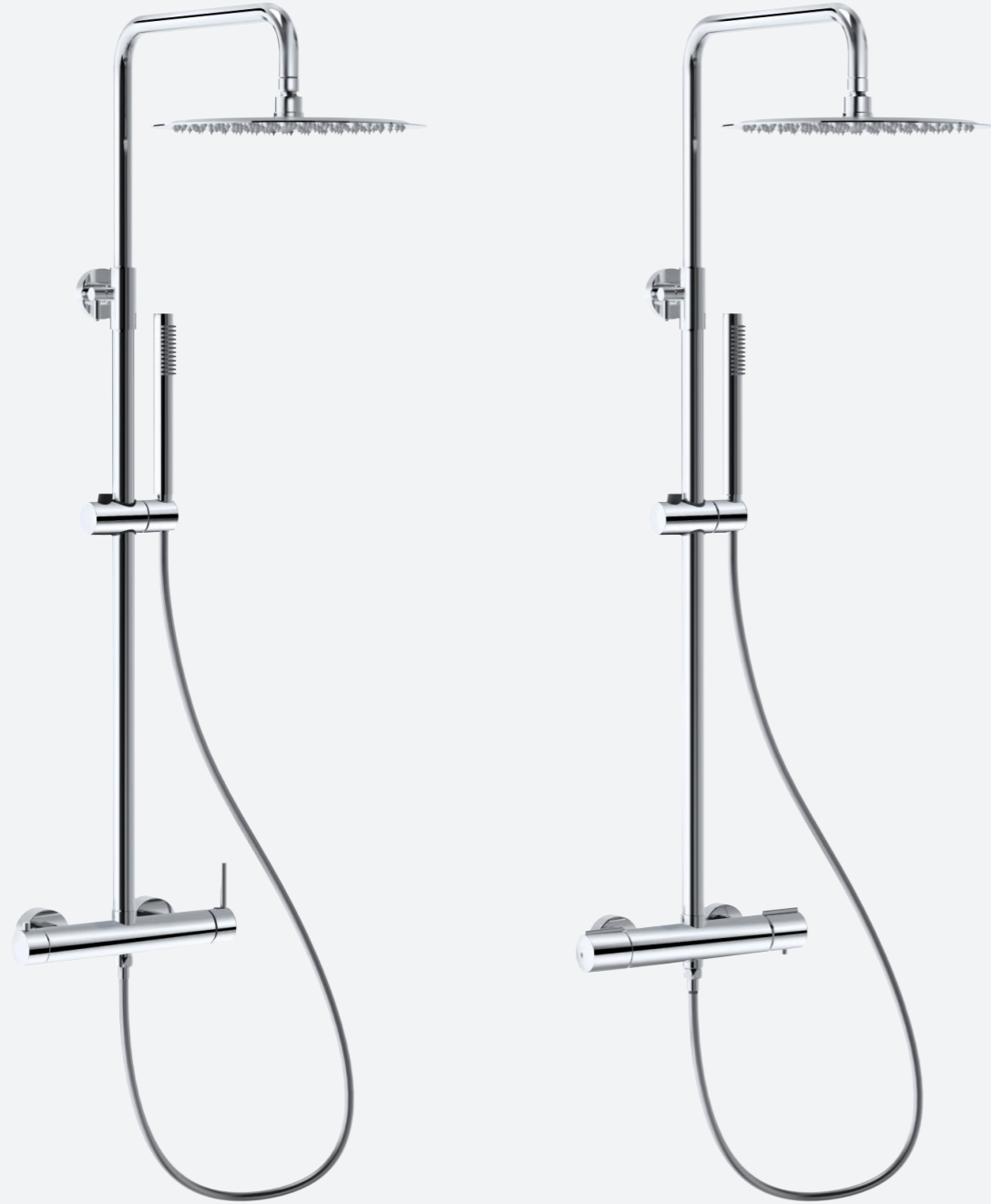

3P 413 S300

Columna ducha cilíndrica telescópica con grifo monomando, ducha de mano, flexo 1,70 m y rociador 300 mm redondo
Cylindrical telescopic shower column with single-lever mixer, hand shower, 1,70 m flexible hose and round 300 mm showerhead
Ensemble mitigeur avec colonne de douche cylindrique télescopique, douchette et flexible de 1,70 m et pomme de douche 300 mm
Цилиндрическая телескопическая душевая стойка с однорычажным смесителем, ручной лейкой, гибким шлангом 1,70 м и верхней лейкой 300 мм

3P 415 S300

Columna ducha cilíndrica telescópica con grifo termostático, ducha de mano, flexo 1,70 m y rociador 300 mm redondo
Cylindrical telescopic shower column with thermostatic mixer, hand shower, 1,70 m flexible hose and round 300 mm showerhead
Ensemble mitigeur thermostatique avec colonne de douche cylindrique télescopique, douchette et flexible de 1,70 m et pomme de douche 300 mm
Цилиндрическая телескопическая душевая стойка с термостатическим смесителем, ручной лейкой, гибким шлангом 1,70 м и верхней лейкой 300 мм

Ducha de mano
Hand shower



3P 130

Toma de agua con soporte, ducha de mano acero inoxidable y flexo 1,70 m
Water outlet with support, stainless steel hand shower and flexible hose 1,70 m
Support avec alimentation, douchette acier inoxydable et flexible 1,70 m
Держатель с подводом воды, с ручным душем из нержавеющей стали, с гибким шлангом 1,70 м



2P Neo

Líneas en equilibrio
Lines in balance



Precisión sin ornamento

Precision without ornament

NEO se crea a partir de líneas definidas que se suavizan en la curva. Un equilibrio preciso entre recta y gesto, entre tensión y fluidez. Donde nada sobra. Todo responde. Una colección sobria y contemporánea, pensada para integrarse con naturalidad en arquitecturas donde el diseño se percibe en los detalles y en la armonía del conjunto.

NEO is created from defined lines that soften into a curve. A precise balance between straightness and gesture, between tension and fluidity. Nothing is superfluous. Everything has a purpose. A sober, contemporary collection designed to integrate naturally into architectures where design is perceived through details and the harmony of the whole.



NG Negro mate / Matt black

CR Cromo / Chrome

2P 002

Monomando lavabo
Wash-basin mixer



NG Negro mate / Matt black

2P Neo ——— MPROJECT



NG Negro mate / Matt black



2P Neo ————— MPROJECT

CR Cromo / Chrome

2P 102

Monomando lavabo alto
High wash-basin mixer

CR
Cromo / Chrome



2P 302

Monomando lavabo empotrado
Built-in single-lever wash-basin mixer

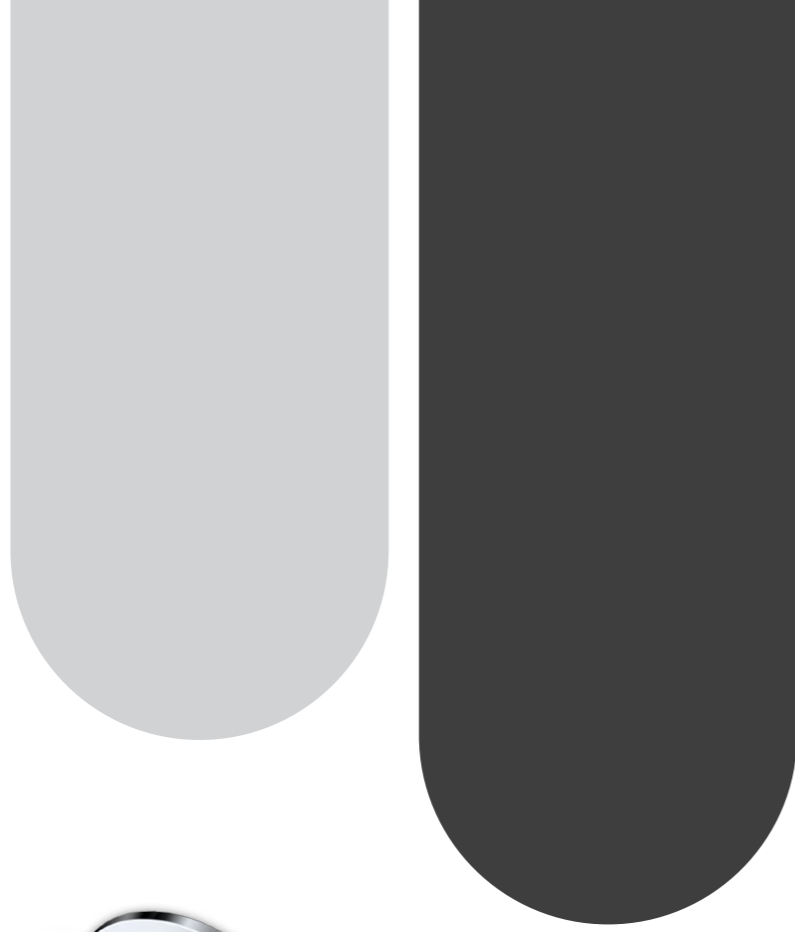

NG
Negro mate / Matt black



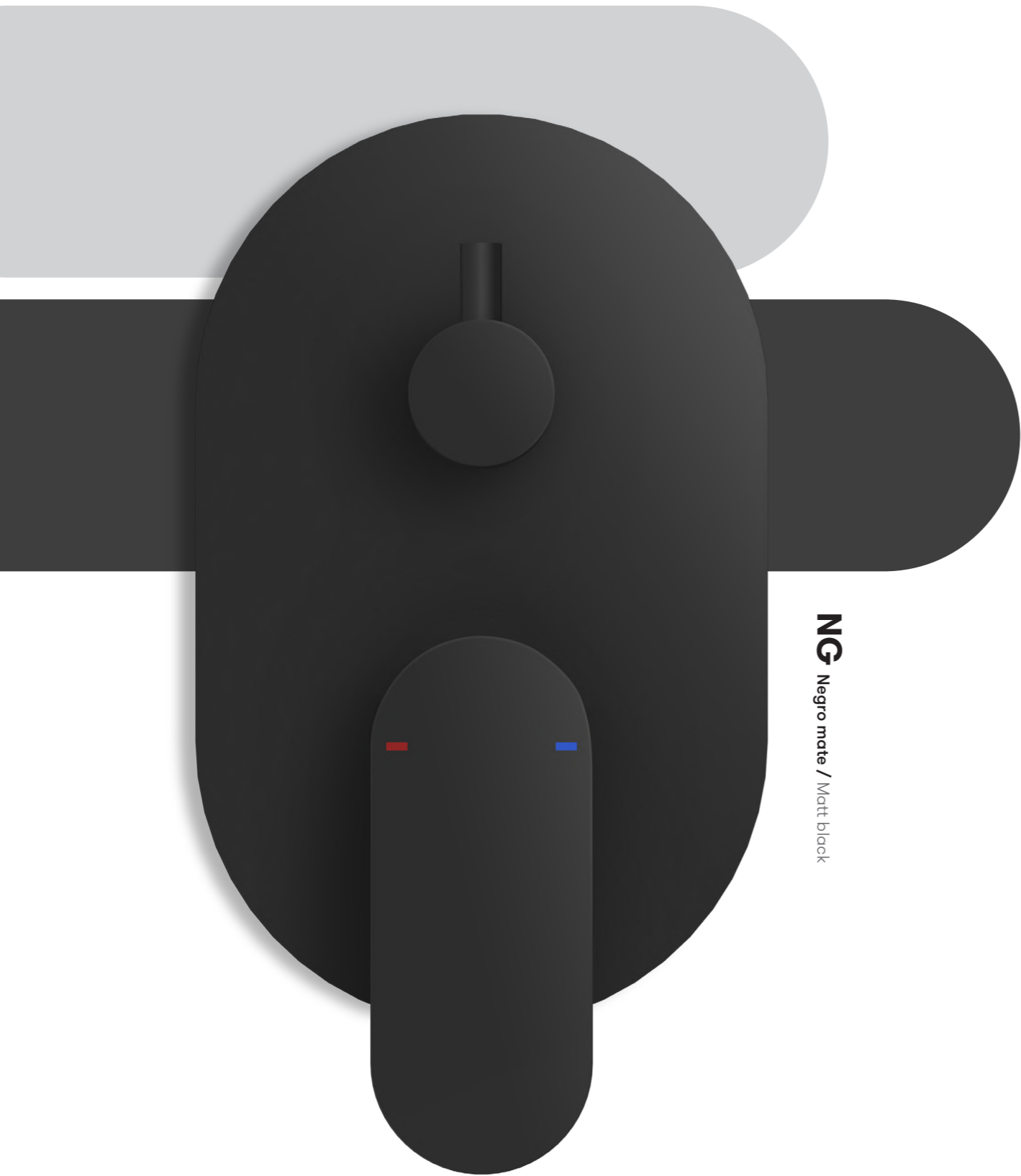

NG Negro mate / Matt black

2P 312

Monomando empotrar baño ducha
Built-in bath shower mixer



CR Cromo / Chrome

2P 315

Monomando empotrar ducha
Built-in shower mixer



NG Negro mate / Matt black

2P 012

Monomando baño ducha con accesorios
Bath and shower mixer with accessories



CR Cromo / Chrome

2P 015

Monomando ducha con accesorios
Shower mixer with accessories

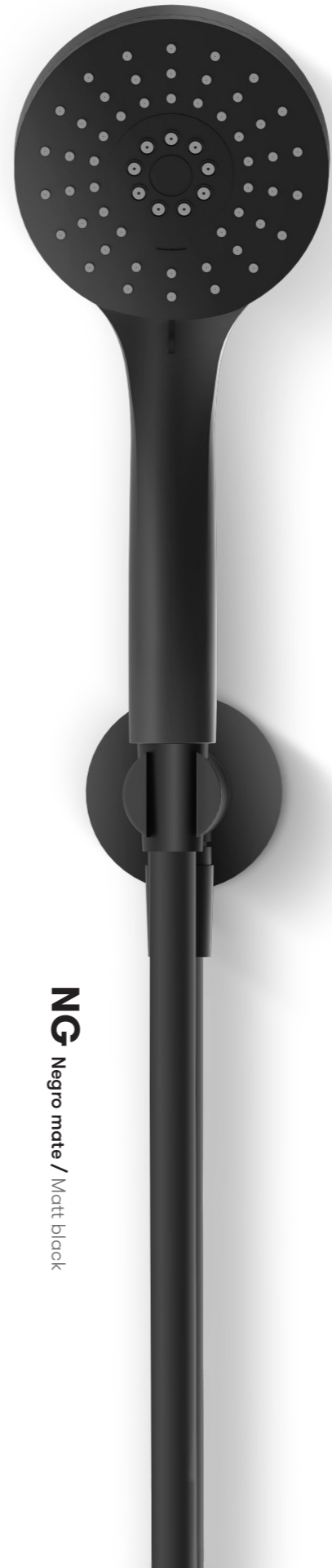

NG Negro mate / Matt black



2P 322 / 2P 323

Conjunto monomando ducha empotrado 2/3 vías con toma con soporte, ducha y flexo 1,70 m

Concealed shower set with shower mixer, diverter 2/3 ways, wall outlet with support, handshower and flexible hose 1,70 m

NG Negro mate / Matt black



2P 413 S300

Columna ducha cilíndrica telescópica con grifo monomando, ducha de mano, flexo 1,70 m y rociador 300 mm redondo

Cylindrical telescopic shower column with single-lever mixer, hand shower, 1,70 m flexible hose and round 300 mm showerhead

CR Cromo / Chrome



2P Neo ——— MPROJECT

2P Neo

Acabados disponibles
Available finishes



CR

Cromo
Chrome
Chrome
Хром



NG

Negro mate
Matt black
Noir mate
Черное

2P Neo

CR

NG

Lavabo
Washbasin



2P 002

Monomando lavabo
Wash-basin mixer
Mitigeur lavabo
Однорычажный Смеситель для раковины

2P 004

Monomando lavabo válv. desag. click-clack
Wash-basin mixer with click-clack waste
Mitigeur lavabo avec vidage click-clack
Однорычажный смеситель для раковины с донным клапаном клик-клак



2P 102

Monomando lavabo alto
High wash-basin mixer
Mitigeur lavabo haut
Однорычажный Смеситель для раковин высокий

2P 104

Monomando lavabo alto válv. desag. click-clack
High wash-basin mixer with click-clack waste
Mitigeur lavabo haut avec vidage click-clack
Однорычажный смеситель для раковины высокий с клапаном клик-клак

Lavabo
Washbasin

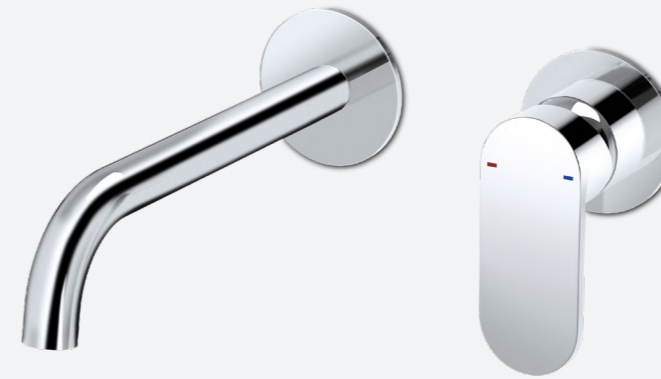

2P 302

Monomando lavabo empotrado, partes externas
Built-in single-lever wash-basin mixer, external parts
Mitigeur lavabo mural à encastrer, partie externe
Встраиваемый однорычажный смеситель для раковины внешняя часть

2P 304

Monomando lavabo empotrado con válv. click-clack, partes externas
Built-in single-lever wash-basin mixer with click-clack waste, external parts
Mitigeur lavabo mural à encastrer avec vidage click-clack, partie externe
Встраиваемый однорычажный смеситель для раковины с клапаном клик-клак внешняя часть

Requiere cuerpo interno **MBOX302** (no incluido)
Requires inner body **MBOX302** (not included)



MBOX302

Cuerpo interno universal con caja de instalación para monomando lavabo empotrado
Universal inner body with installation box for built-in single-lever wash-basin mixer
Corps d'encastrement universel avec boîtier d'installation pour mitigeur lavabo à encastrer
Универсальная внутренняя часть со встраиваемой коробкой для встроенного однорычажного смесителя для раковины

2P Neo

CR

NG

Bidé
Bidet



2P 009

Monomando bidé
Bidet mixer
Mitigeur bidet
Однорычажный смеситель для биде

2P 011

Monomando bidé vál. desag. click-clack
Bidet mixer with click-clack waste
Mitigeur bidet avec vidage click-clack
Однорычажный смеситель для биде с клапаном клик-клак

Baño ducha
Bath tub



2P 012

Monomando baño ducha con accesorios
Bath and shower mixer with accessories
Mitigeur bain-douche avec accessoires
Смеситель для ванны и душа с держателем ручного душа

Ducha
Shower



2P 015

Monomando ducha con accesorios
Shower mixer with accessories
Mitigeur douche avec ensemble de douche
Смеситель для душа с держателем ручного душа

2P Neo



Baño ducha
Bath tub



2P 312

Monomando baño ducha empotrado, partes externas
Built-in bath shower mixer, external parts
Mitigeur bain-douche à encastrer, partie externe
Встроенный смеситель для ванны и душа внешняя часть

Requiere cuerpo interno **MBOX312** (no incluido)
Requires inner body **MBOX312** (not included)

MBOX312

Cuerpo interno universal con caja de instalación para monomando baño ducha empotrado
Universal inner body with installation box for built-in single-lever bath shower mixer
Corps d'encastrement universel avec boîtier d'installation pour mitigeur bain-douche à encastrer
Универсальная внутренняя часть со встраиваемой коробкой для встроенного однорычажного смесителя для раковины

Ducha
Shower

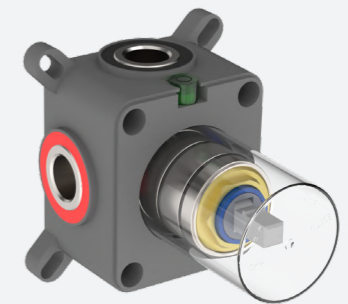

2P 315

Monomando ducha empotrado, partes externas
Built-in shower mixer, external parts
Mitigeur douche à encastrer, partie externe
Встроенный смеситель для душа внешняя часть

Requiere cuerpo interno **MBOX315** (no incluido)
Requires inner body **MBOX315** (not included)

MBOX315

Cuerpo interno universal con caja de instalación para monomando ducha empotrado
Universal inner body with installation box for built-in single-lever shower mixer
Corps d'encastrement universel avec boîtier d'installation pour mitigeur douche à encastrer
Универсальная внутренняя часть со встраиваемой коробкой для встроенного однорычажного смесителя для раковины

2P Neo



Baño ducha
Bath tub



2P 322 / 2P 323

Conjunto monomando ducha empotrado 2/3 vías con toma con soporte, ducha y flexo 1,70 m, partes externas
Concealed shower set with shower mixer, diverter 2/3 ways, wall outlet with support, handshower and flexible hose 1,70 m, external parts
Ensemble mitigeur de douche 2/3 voies avec coude mural et support, douche et flexible de 1,70 m, partie externe
Встроенный душевой гарнитур со смесителем для душа, переключателем на 2/3 выхода, настенным выпуском с держателем ручного душа и гибким шлангом 1,70 м

Requiere cuerpo interno **MBOX322/MBOX323** (no incluido)
Requires inner body **MBOX322/MBOX323** (not included)

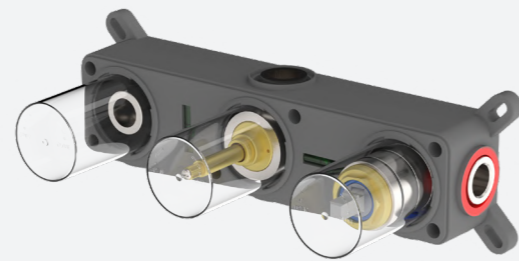

MBOX322

Cuerpo interno universal con caja de instalación para conjunto monomando ducha empotrado 2 vías
Universal inner body with installation box for 2-way built-in single-lever shower mixer
Corps d'encastrement universel avec boîtier d'installation pour mitigeur douche à encastrer 2 voies
Универсальная внутренняя часть со встраиваемой коробкой для встроенного однорычажного смесителя для душа на 2 потока

MBOX323

Cuerpo interno universal con caja de instalación para conjunto monomando ducha empotrado 3 vías
Universal inner body with installation box for 3-way built-in single-lever shower mixer
Corps d'encastrement universel avec boîtier d'installation pour mitigeur douche à encastrer 3 voies
Универсальная внутренняя часть со встраиваемой коробкой для встроенного однорычажного смесителя для душа на 3 потока

Baño ducha
Bath tub



2P 312 S300

Conjunto monomando baño ducha empotrado con toma con soporte, ducha de mano y flexo 1,70 m con brazo de ducha pared y rociador 300 mm redondo, partes externas
Built-in single-lever bath/shower mixer with wall outlet with support, hand shower and 1,70 m flexible hose, round 300 mm showerhead and wall arm, external parts
Mitigeur bain-douche à encastrer avec support douchette avec alimentation, flexible 1,70 m et pomme de douche de 300 mm avec bras de douche rond, partie externe
Встроенный однорычажный смеситель для ванны/душа, с подводом воды и держателем, ручным душем, гибким шлангом 1,70 м, с крыгой верхней лейкой 300 мм, с держателем из стены, внешние части

Requiere cuerpo interno **MBOX312** (no incluido)
Requires inner body **MBOX312** (not included)



2P 322 S300 / 2P 323 S300

Conjunto monomando ducha empotrado con inversor 2/3 vías, toma con soporte, ducha de mano y flexo 1,70 m, brazo de ducha pared y rociador 300 mm redondo, partes externas
Built-in single-lever shower mixer with diverter 2/3 ways, wall outlet with support, hand shower and 1,70 m flexible hose, round 300 mm showerhead and wall arm, external parts
Ensemble mitigeur douche à encastrer avec inverseur 2/3 voies, avec support douchette et alimentation, flexible 1,70 m et pomme de douche 300 mm avec bras de douche rond, partie externe
Встроенный однорычажный смеситель для душа с переключателем на 2/3 потока с подводом воды, ручным душем, гибким шлангом 1,70 м, с крыгой верхней лейкой 300 мм, с держателем из стены, внешние части

Requiere cuerpo interno **MBOX322/MBOX323** (no incluido)
Requires inner body **MBOX322/MBOX323** (not included)

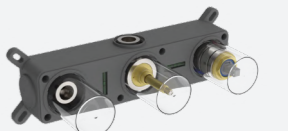

2P Neo

CR

NG

Columna ducha
Shower column



2P 413 S300

Columna ducha cilíndrica telescópica con grifo monomando, ducha de mano, flexo 1,70 m y rociador 300 mm redondo
Cylindrical telescopic shower column with single-lever mixer, hand shower, 1,70 m flexible hose and round 300 mm showerhead
Ensemble mitigeur avec colonne de douche cylindrique télescopique, douchette et flexible de 1,70 m et pomme de douche 300 mm
Цилиндрическая телескопическая душевая стойка с однорычажным смесителем, ручной лейкой, гибким шлангом 1,70 м и верхней лейкой 300 мм

Ducha de mano
Hand shower



2P 130

Toma de agua con soporte, ducha de mano 3 funciones ABS y flexo 1,70 m
Water outlet with support, 3-function hand shower ABS and flexible hose 1,70 m
Support avec alimentation, douchette ABS 3 fonctions et flexible 1,70 m
Держатель с подводом воды, с ручным душем из ABS, с 3-мя переключениями воды, с гибким шлангом 1,70 м





3P Kitchen

La forma del movimiento
The Shape of Movement



Precisión en cada uso

Precision in every use

Kitchen combina ergonomía, resistencia y diseños cilíndricos que aportan continuidad y presencia al espacio. La colección incorpora distintas configuraciones, caño giratorio y versión de caño extraíble que amplían la versatilidad en la zona más activa del hogar. Pensada para una larga durabilidad. Preparada para el ritmo real de la cocina.

Kitchen combines ergonomics, durability, and cylindrical designs that bring continuity and presence to the space. The collection includes different configurations, a swivelling spout, and a pull-out spout version that enhance versatility in the most active area of the home. Designed for long-lasting durability. Ready for the real pace of the kitchen.



3P 064

Monomando cocina
Sink Mixer

NG Negro mate / Matt black



3P 084

Monomando cocina con ducha extraíble de 2 funciones
Sink Mixer pull-out spray 2 jets

OCP Oro cepillado PVD / Brushed gold PVD

3P Kitchen

Acabados disponibles
Available finishes



INOX

Acero Inoxidable
Stainless Steel
Acier Inoxydable
Нержавеющая сталь

CR

Cromo
Chrome
Chrome
Хром

NG

Negro mate
Matt black
Noir mate
Черное

OCP

Oro cepillado PVD
Brushed gold PVD
Or brossé PVD
Брашированное
золото PVD

GCP

Grafito Cepillado PVD
Brushed gun metal PVD
Graphite brossé PVD
матовый металл PVD

CCP

Cobre cepillado PVD
Brushed copper PVD
Cuivre brossé PVD
Матовая медь PVD

MCP

Marrón café cepillado PVD
Brushed coffee brown PVD
Marron café brossé PVD
Матовый кофейно-коричневый PVD

3P Kitchen

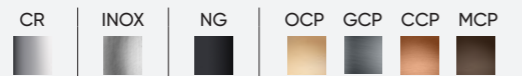

Cocina
Kitchen



3P 064

Monomando cocina
Sink Mixer
Mitigeur évier
Einhebel-Küchenmischer
смеситель для кухни

3P 084

Monomando cocina con ducha extraíble de 2 funciones
Sink Mixer pull-out spray 2 jets
Mitigeur évier douchette extractible 2 fonctions
Einhebel-Küchenmischer Ausziehbrause 2 jet
смеситель для кухни с вытяжным душем. 2 виды струи





6H Hydrotherapy

El agua como experiencia
Water as an Experience



Más que uso. Sensación

More than use. Sensation

Hydrotherapy lleva el bienestar al baño.
 Proporciones equilibradas, diseño preciso y distintos acabados que se integran y complementan con naturalidad en el espacio.
 Elementos pensados para elevar el confort.

Hydrotherapy brings well-being to the bathroom.
 Balanced proportions, precise design, and various finishes that naturally integrate and complement the space.
 Elements designed to elevate comfort.

Puedes elegir dos diámetros diferentes de rociador Ø250mm o Ø300mm y combinarlo con dos tipos de brazo, a pared o a techo, podrás elegir entre 7 acabados diferentes.

You can choose between two showerhead sizes, Ø250 mm or Ø300 mm, and combine them with either a wall or ceiling-mounted arm, available in 7 different finishes.

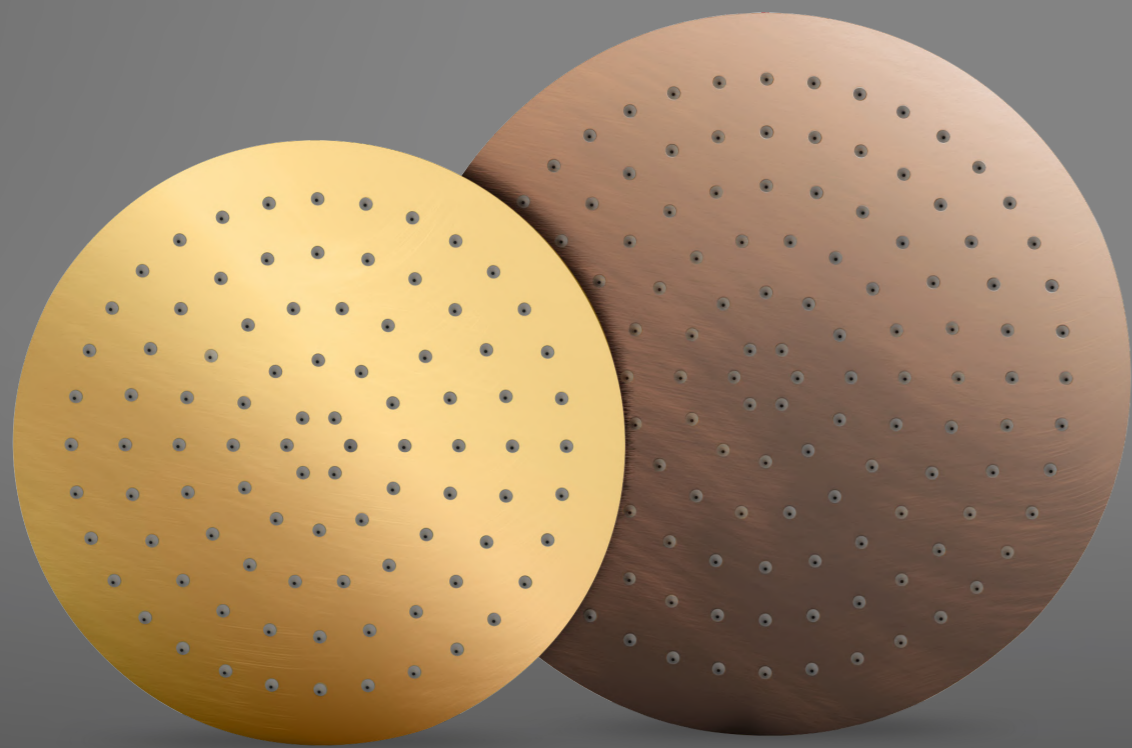

OCP Oro cepillado PVD / Brushed gold PVD

MCP Marrón café cepillado PVD / Brushed coffee brown PVD

6H S250

Rociador ducha redondo acero inoxidable 250 mm h 2 mm
Round showerhead stainless steel 250 mm h 2 mm

6H S300

Rociador ducha redondo acero inoxidable 300 mm h 2 mm
Round showerhead stainless steel 300 mm h 2 mm

INOX Acero inoxidable / Stainless steel



CR Cromo / Chrome



NG Negro mate / Matt black

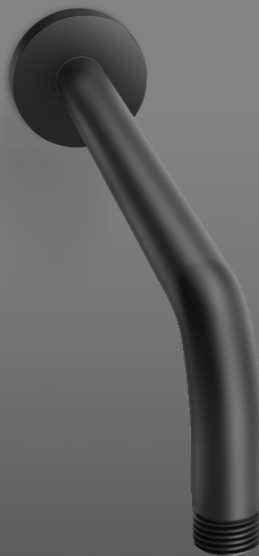

OCP Oro cepillado PVD / Brushed gold PVD



GCP Grafito cepillado PVD / Brushed gun metal PVD



GCP Cobre cepillado PVD / Brushed copper PVD



MCP Marrón café cepillado PVD / Brushed coffee brown PVD



6H 180

Brazo ducha pared redondo 1/2" 35 cm
Round wall arm 1/2" 35 cm

6H 181

Brazo ducha techo redondo 1/2" 20 cm
Round ceiling arm 1/2" 20 cm

NG
Negro mate / Matt black



2P 130

Toma de agua con soporte, ducha de mano 3 funciones ABS y flexo 1,70 m
Water outlet with support, 3-function hand shower ABS and flexible hose 1,70 m

GCP
Grafito cepillado PVD / Brushed gun metal PVD



3P 130

Toma de agua con soporte, ducha de mano acero inoxidable y flexo 1,70 m
Water outlet with support, stainless steel hand shower and flexible hose 1,70 m



NG
Negro mate / Matt black

6H Hydrotherapy

MPROJECT



MCP Marrón café cepillado PVD / Brushed coffee brown PVD

6H 850

Monomando bidé empotrado con soporte, duchita higiénica y flexo 1,20 m
Concealed single-lever bidet set with support, shut-off hand shower and flexible hose 1,20 m



OCP Oro cepillado PVD / Brushed gold PVD

6H 950

Monomando bidé empotrado con soporte, duchita higiénica y flexo 1,20 m
Concealed single-lever bidet set with support, shut-off hand shower and flexible hose 1,20 m



CCP Cobre cepillado PVD / Brushed copper PVD



6H 529

Grifo de 2 aguas bidé con soporte, duchita higiénica y flexo 1,20 m
Tap 2 water bidet set with support, shut-off handshower and flexible hose 1,20 m

INOX Acero inoxidable / Stainless steel



6H 528

Grifo de 1 agua bidé con soporte, duchita higiénica y flexo 1,20 m
Tap 1 water bidet set with support, shut-off handshower and flexible hose 1,20 m

OCP Oro cepillado PVD / Brushed gold PVD





GCP Grafito cepillado PVD / Brushed gun metal PVD

6H 160

Caño bañera mural cilíndrico 1/2"
Round wall bath tub spout 1/2"



MCP Marrón café cepillado PVD / Brushed coffee brown PVD

6H Hydrotheraphy

Acabados disponibles
Available finishes

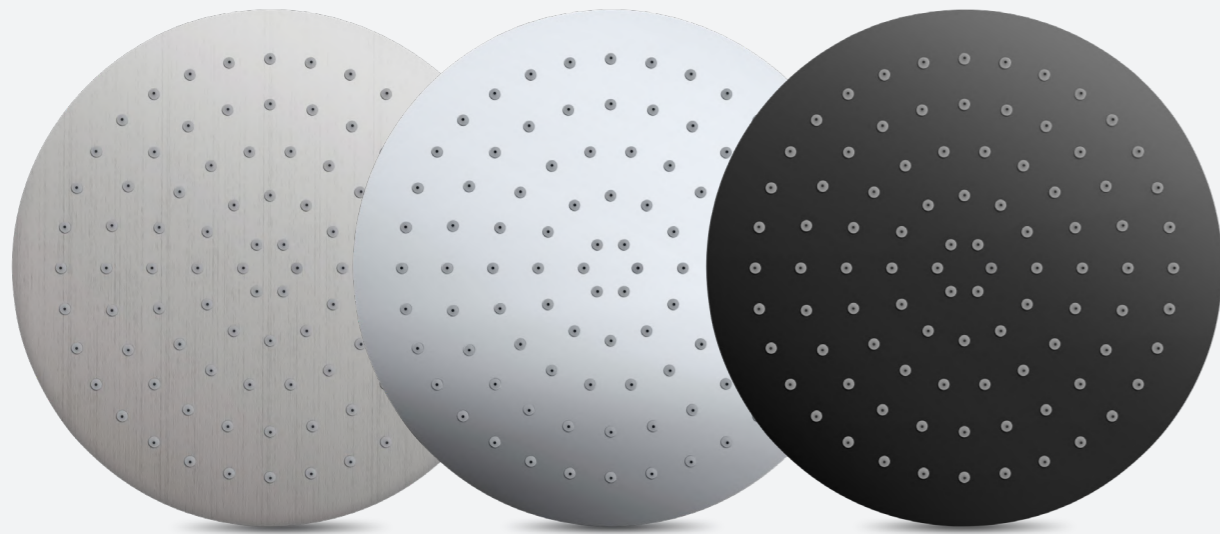

INOX

Acero Inoxidable
Stainless Steel
Acier Inoxydable
Нержавеющая сталь

CR

Cromo
Chrome
Chrome
Хром

NG

Negro mate
Matt black
Noir mate
Черное

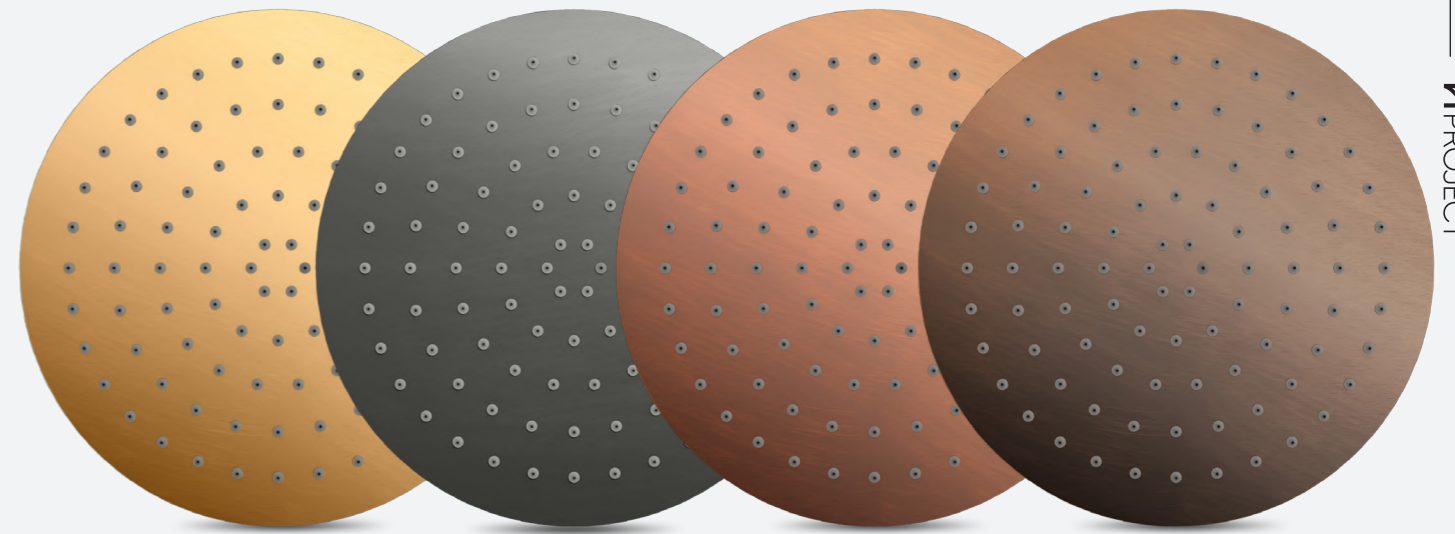

OCP

Oro cepillado PVD
Brushed gold PVD
Or brossé PVD
Брашированное
золото PVD

GCP

Grafito Cepillado PVD
Brushed gun metal PVD
Graphite brossé PVD
матовый металл PVD

CCP

Cobre cepillado PVD
Brushed copper PVD
Cuivre brossé PVD
Матовая медь PVD

MCP

Marrón café cepillado PVD
Brushed coffee brown PVD
Marron café brossé PVD
Матовый кофейно-коричневый PVD

6H Hydrotheraphy



Rociador ducha
Shower head

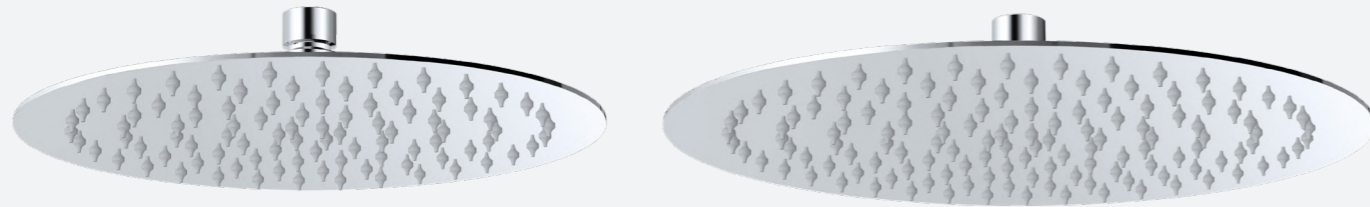

6H S250

Rociador ducha redondo acero inoxidable 250 mm h 2mm
Round showerhead stainless steel 250 mm h 2mm
Pomme de douche ronde en acier inoxydable 250 mm h 2mm
Распылитель душ круглый латунь д250 мм h 2mm

6H S300

Rociador ducha redondo acero inoxidable 300 mm h 2mm
Round showerhead stainless steel 300 mm h 2mm
Pomme de douche ronde en acier inoxydable 300 mm h 2mm
Распылитель душ круглый латунь д300 мм h 2mm

Brazo ducha
Shower arm



6H 180

Brazo ducha pared redondo 1/2" 35 cm
Round wall arm 1/2" 35 cm
Bras de douche sortie mural rond 1/2" x 35 cm
Горизонтальный поворотный душевой кронштейн стена 1/2" 35 см

6H 181

Brazo ducha techo redondo 1/2" 20 cm
Round ceiling arm 1/2" 20 cm
Bras de douche vertical rond 1/2" 20 cm
Вертикальный душевой кронштейн 1/2" 20 см

6H Hydrotheraphy



Ducha de mano
Hand shower



2P 130

Toma de agua con soporte, ducha de mano 3 funciones ABS y flexo 1,70 m
Water outlet with support, 3-function hand shower ABS and flexible hose 1,70 m
Support avec alimentation, douchette ABS 3 fonctions et flexible 1,70 m
Держатель с подводом воды, с ручным душем из ABS, с 3-мя переключенными воды, с гибким шлангом 1,70 м

5P 130

Toma de agua con soporte, ducha de mano 3 funciones ABS y flexo 1,70 m
Water outlet with support, 3-function hand shower ABS and flexible hose 1,70 m
Support avec alimentation, douchette ABS 3 fonctions et flexible 1,70 m
Держатель с подводом воды, с ручным душем из ABS, с 3-мя переключенными воды, с гибким шлангом 1,70 м

Ducha de mano
Hand shower



3P 130

Toma de agua con soporte, ducha de mano acero inoxidable y flexo 1,70 m
Water outlet with support, stainless steel hand shower and flexible hose 1,70 m
Support avec alimentation, douchette acier inoxydable et flexible 1,70 m
Держатель с подводом воды, с ручным душем из нержавеющей стали, с гибким шлангом 1,70 м

Caño
Spout



6H 160

Caño bañera mural cilíndrico 1/2"
Round wall bath tub spout 1/2"
Bec fondu pour baignoire 1/2" rond
Круглый излив для ванны 1/2"

6H Hydrotheraphy



Bidé empotrado
WC mixer



6H 850

Monomando bidé empotrado con soporte, duchita higiénica y flexo 1,20 m
Concealed single-lever bidet set with support, shut-off hand shower and flexible hose 1,20 m
Mitigeur de bidet à encastrer avec support, douchette et flexible 1,20 m
Однорычажный гигиенический гарнитур с держателем душевой лейки и гибким шлангом 1,20 м

6H 950

Monomando bidé empotrado con soporte, duchita higiénica y flexo 1,20 m
Concealed single-lever bidet set with support, shut-off hand shower and flexible hose 1,20 m
Mitigeur de bidet à encastrer avec support, douchette et flexible 1,20 m
Однорычажный гигиенический гарнитур с держателем душевой лейки и гибким шлангом 1,20 м



Bidé empotrado
WC mixer



6H 528

Grifo de 1 agua bidé con soporte, duchita higiénica y flexo 1,20 m
Tap 1 water bidet set with support, shut-off handshower and flexible hose 1,20 m
Ensemble avec robinet 1 eau avec support, douchette ronde, flexible 1,20 m
Гигиенический душ с запорным краном, лейкой и гибким шлангом 1,20 м

6H 529

Grifo de 2 aguas bidé con soporte, duchita higiénica y flexo 1,20 m
Tap 2 water bidet set with support, shut-off handshower and flexible hose 1,20 m
Ensemble avec robinet 2 eaux avec support, douchette ronde, flexible 1,20 m
Гигиенический душ с запорным краном, лейкой и гибким шлангом 1,20 м



6H Hydrotheraphy



Duchitas
Shut-off hand shower



6H 800

Kit duchita redondo, flexo EPDM 1,20 m, llave de cierre cerámico y soporte
Round shut-off hand shower set, EPDM flexible hose of 1,20 m, angle valve with ceramic headwork and support
Ensemble douchette ronde, flexible de douche EPDM 1,20 m, robinet d'arrêt ceramique et support murale
Набор гигиенического душа круглый с гибким шлангом EPDM 1,20 м и с держателем, керамический запорный кран

6H 900

Kit duchita cuadrado, flexo EPDM 1,20 m, llave de cierre cerámico y soporte
Square shut-off hand shower set, EPDM flexible hose of 1,20 m, angle valve with ceramic headwork and support
Ensemble douchette carré, flexible de douche EPDM 1,20 m, robinet d'arrêt ceramique et support murale
Набор гигиенического душа квадратный с гибким шлангом EPDM 1,20 м и с держателем, керамический запорный кран

Complementos
Complements



6H 607

Sifón botella lavabo minimalista
Basin trap round
Siphon rond
Сифон круглый



6H 600

Válvula click-clack 1 1/4 redonda con y sin rebosadero
Click-clack waste round
Vidage click-clack rond
Донный клапан клик-клак 1 1/4 круглый



3A Accessories

El valor del detalle
The Value of Detail



Cada detalle cuenta Every detail matters

Accesorios de líneas cilíndricas que consolidan la identidad del espacio.
Distintos acabados que permiten mantener continuidad estética en cada proyecto.

Cylindrical-lined accessories that reinforce the identity of the space.
A range of finishes that ensure aesthetic continuity in every project.

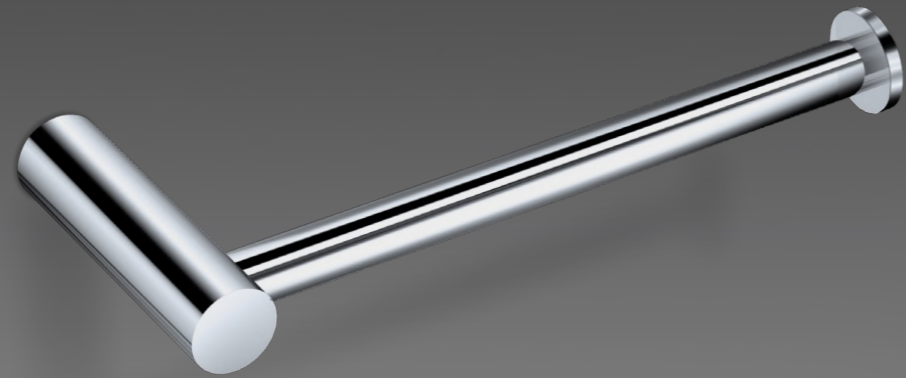

CR Cromo / Chrome

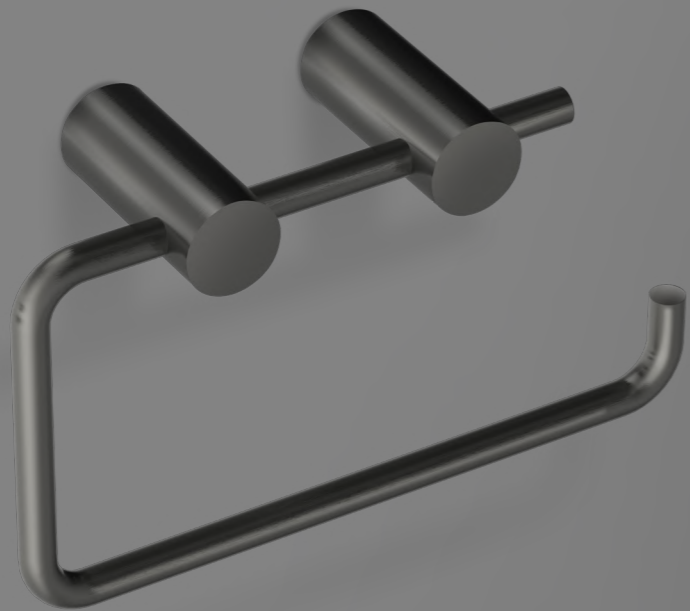

GCP Grafito cepillado PVD / Brushed gun metal PVD

3A 011

Portarrollos lateral
Roll holder

3A 041

Portarrollos
Roll holder



GCP Cobre cepillado PVD / Brushed copper PVD



NG Negro mate / Matt black

3A 114

Toallero estante 60 cm
Towel holder stand 60 cm

3A 004L

Toallero barra 60 cm
Towel bar large 60 cm



3A 006

Portavaso pared cristal
Tumbler holder

3A 007

Jabonera pared cristal
Soap dish holde

MCP Marrón café cepillado PVD / Brushed coffee brown PVD



3A Accessories

MPROJECT

OCP Oro cepillado PVD / Brushed gold PVD

3A Accessories

Acabados disponibles
Available finishes

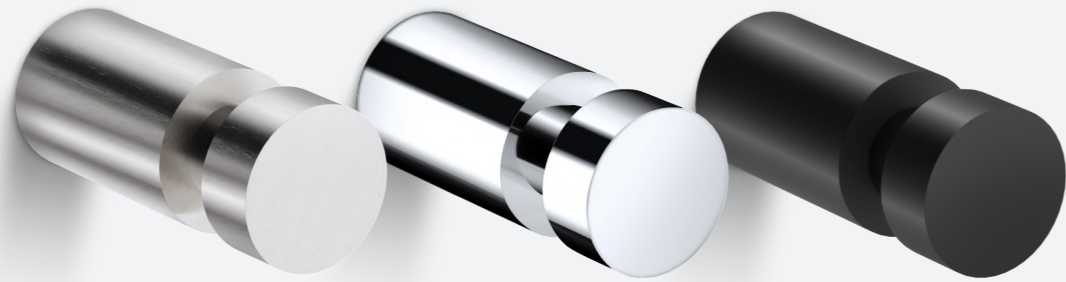

INOX

Acero Inoxidable
Stainless Steel
Acier Inoxydable
Нержавеющая сталь

CR

Cromo
Chrome
Chrome
Хром

NG

Negro mate
Matt black
Noir mate
Черное

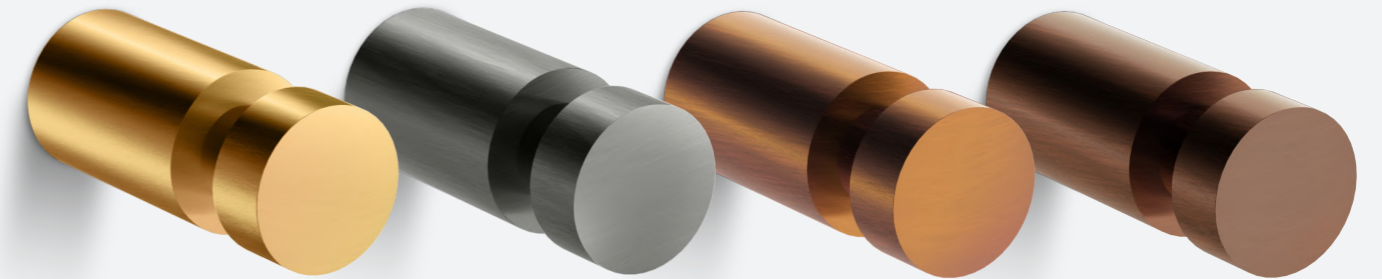

OCP

Oro cepillado PVD
Brushed gold PVD
Or brossé PVD
Брашированное
золото PVD

GCP

Grafito Cepillado PVD
Brushed gun metal PVD
Graphite brossé PVD
матовый металл PVD

CCP

Cobre cepillado PVD
Brushed copper PVD
Cuivre brossé PVD
Матовая медь PVD

MCP

Marrón café cepillado PVD
Brushed coffee brown PVD
Marron café brossé PVD
Матовый кофейно-коричневый PVD

3A Accessories



Baño
Bathroom

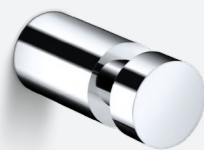

3A 005

Percha
Wall hook
Porte-peignoir
Крючок на стену

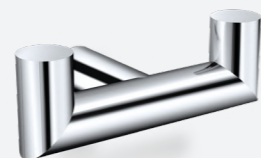

3A 015

Percha doble
Double wall hook
Porte-peignoir double
Двойной настенный крючок



3A 041

Portarrollos
Roll holder
Porte-papier
Бумагодержатель

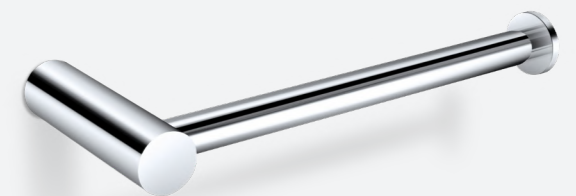

3A 011

Portarrollos lateral
Roll holder
Porte-papier
Бумагодержатель

3A Accessories



Baño
Bathroom



3A 004M

Toallero barra 40 cm
Towel bar small 40 cm
Porte-serviette 40 cm
Держатель для полотенца маленький 40 cm

3A 004L

Toallero barra 60 cm
Towel bar large 60 cm
Porte-serviette 60 cm
Держатель для полотенца маленький 60 cm

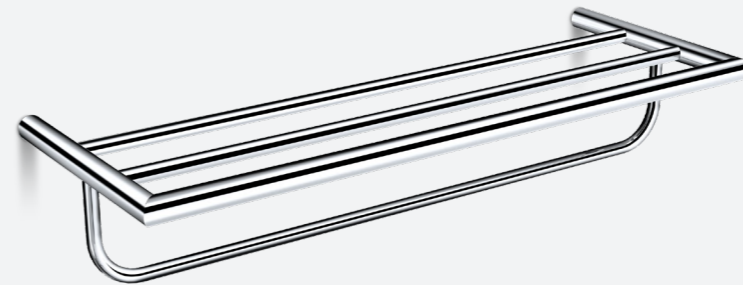

3A 114

Toallero estante 60 cm
Towel holder stand 60 cm
Porte-serviettes 60 cm
Держатель для полотенец 60 cm



3A 008

Portaescobillas a pared
Wall mounted brush holder
Ensemble pot à balai mural
Ёршик настенный

3A Accessories



Baño
Bathroom



3A 006

Portavaso pared cristal
Tumbler holder
Porte-verre mural
Стакан держатель



3A 007

Jabonera pared cristal
Soap dish holder
Porte-savon mural
Мыльница



Condiciones Generales

1. PRECIOS

Los precios de la lista de precios o de cualquier anexo que publiquemos, deben ser considerados precios recomendados de venta al público (PVP) antes de impuestos. Los precios están sujetos a cualquier modificación debido a las circunstancias del mercado, materias primas, mano de obra, impuestos, etc. Griferías Maier, S.L. (Maier) comunicará a sus clientes cualquier cambio que se produzca a través de las vías de comunicación habituales (representantes, email, etc.). Esta lista de precios anula y sustituye todas las precedentes.

2. PEDIDOS Y ACEPTACIÓN DE CONDICIONES

Con la realización de un pedido, el cliente acepta tácitamente todas las condiciones abajo expuestas. El pedido está sujeto a la aceptación o anulación por parte de Maier.

3. PLAZO DE ENTREGA

El plazo de entrega es siempre aproximado y Maier no se hace responsable de las consecuencias debidas a cualquier retraso. El cliente dispone de un periodo de (1) mes para recoger la mercancía una vez que se le notifique que está preparada; sobrepasar dicho plazo conllevaría a aplicar cargos adicionales.

4. DISEÑO

Nuestros productos podrán ser modificados por exigencias de diseño, sin previo aviso, siempre para mejorar con ello el producto final. El material gráfico y/o el diseño impreso en los catálogos, tarifas, folletos y demás soportes publicitarios tienen valor indicativo, por lo que el cliente no podrá acogerse a ellos en caso de posibles quejas por disconformidad o diferencia con los productos suministrados. Las reclamaciones al respecto deberán realizarse, como máximo, en los quince (15) días naturales siguientes a la entrega de la mercancía en destino.

5. EXPEDICIONES

Incluso a portes pagados, la mercancía siempre viaja por cuenta y riesgo del comprador. El destinatario, comprobará, al recibo de la mercancía, el estado de la misma, indicando en el albarán del transportista las posibles incidencias.

6. DEVOLUCIONES

Maier no admitirá devoluciones de material que anteriormente no se hayan acordado y autorizado por nuestro Representante o Dirección. Los envíos de mercaderías a devolver deberán efectuarse a portes pagados por el cliente. Maier no aceptará ninguna devolución de mercancía fuera de las coberturas y plazos de nuestra garantía. En caso de recibir la mercancía en perfectas condiciones, esta sufrirá una depreciación del 20% si es de hace menos de 1 año, 40% en el caso de más de 1 año y del 60% si es de más de 2 años.

7. GARANTÍA

Griferías Maier, S.L. garantiza todos sus productos contra defecto de fabricación, materiales y componentes por un plazo de 5 años, contados desde la fecha de compra.

Cualquier anomalía producida por mal uso, manipulaciones, instalaciones incorrectas, implantaciones de recambios no originales, así como la acción producida por elementos extraños conducidos por el agua, dejará sin efecto esta garantía.

La garantía en los acabados superficiales es de 5 años para el cromo y 3 años para el resto de los acabados de nuestro catálogo.

La garantía no incluye los portes ni los posibles costes de la mano de obra en la sustitución de piezas ni la reparación de daños que ocasionalmente pudieran producirse.

Para cualquier reclamación, adjuntar la tarjeta de garantía que viene en la caja del producto y una copia de la factura con la fecha de compra.

8. RESERVA DE DOMINIO

Maier será propietario de todos los productos suministrados al cliente hasta el cobro completo de la factura correspondiente.

9. PROPIEDAD INTELECTUAL

Todas las imágenes e ilustraciones contenidas en este catálogo o tarifa son propiedad de Maier. No se permite el uso de las mismas a terceras personas sin la autorización expresa de Maier.

10. JURISDICCIÓN

La buena fe que impera en las relaciones de Maier con sus clientes y nuestro deseo de resolver cualquier diferencia por vía amistosa, no hacen pensar en cualquier reclamación judicial. Sin embargo, en la improbable situación que se dé el caso, ambas partes deberán someterse única y exclusivamente a los tribunales de Barcelona (España).

General terms and conditions

1. PRICES

The prices listed in the price list or in any annex we publish are to be regarded as recommended retail prices (PVP) excluding taxes. Prices are subject to change due to market conditions, depending on raw materials, labour costs, taxes, etc.

Griferías Maier, S.L. (Maier) will notify its customers of any changes through the usual channels of communication (sales representatives, email, etc.). This price list supersedes and replaces all previous versions.

2. ORDERS AND ACCEPTANCE OF TERMS AND CONDITIONS

When placing an order, the customer tacitly accepts all the terms and conditions set out below. The order is subject to acceptance or cancellation by Maier.

3. DELIVERY TIME

The delivery time is always approximate and Maier accepts no liability for the consequences of any delay.

The customer has a period of one (1) month to collect the goods once notified that they are ready; exceeding this period will result in additional charges.

4. DESIGN

Our products may be modified based on design requirements, without prior notice, provided that such changes serve to improve the final product. The graphic material and/or design printed in catalogues, price lists, brochures and other advertising materials are for illustrative purposes only; therefore, the customer may not rely on them in the event of any complaints regarding discrepancies or differences with the products supplied. Any complaints in this regard must be made within a maximum of fifteen (15) calendar days following delivery of the goods to their destination.

5. SHIPMENTS

Even on carriage paid terms, the goods always travel at the buyer's risk and expense. Upon receipt of the goods, the recipient shall check their condition, noting any issues on the carrier's delivery note.

6. RETURNS

Maier will not accept returns of goods that have not been previously agreed and authorised by our Representative or Management. For goods to be returned carriage must be paid by the customer. Maier will not accept any returns of goods beyond the scope and time limits of our warranty. If the goods are received in perfect condition, they will be subject to a 20% depreciation if they are less than 1 year old, 40% if they are more than 1 year old, and 60% if they are more than 2 years old.

7. WARRANTY

Griferías Maier, S.L. guarantees all its products against manufacturing defects, materials and components for a period of 5 years from the date of purchase.

This warranty shall be void in the event of any fault caused by misuse, tampering, incorrect installation, the fitting of non-original spare parts, or damage caused by external elements carried in the water.

The warranty on surface finishes is 5 years for chrome and 3 years for all other finishes in our catalogue.

The warranty does not cover delivery costs or any labour costs incurred in the replacement of parts or the repair of damage that may occasionally occur.

For any claim, please enclose the warranty card included in the product box and a copy of the invoice showing the date of purchase.

8. RETENTION OF TITLE

Maier shall retain ownership of all products supplied to the customer until the corresponding invoice has been paid in full.

9. INTELLECTUAL PROPERTY

All images and illustrations contained in this catalogue or price list are the property of Maier. Their use by third parties is not permitted without the express authorisation of Maier.

10. JURISDICTION

The spirit of good faith that characterises Maier's relationships with its clients and our desire to resolve any disputes amicably do not suggest that legal action would be taken. However, in the unlikely event that such a situation should arise, both parties shall submit exclusively to the courts of Barcelona (Spain).

MPROJECT

contact@m-project.es
Barcelona - Spain

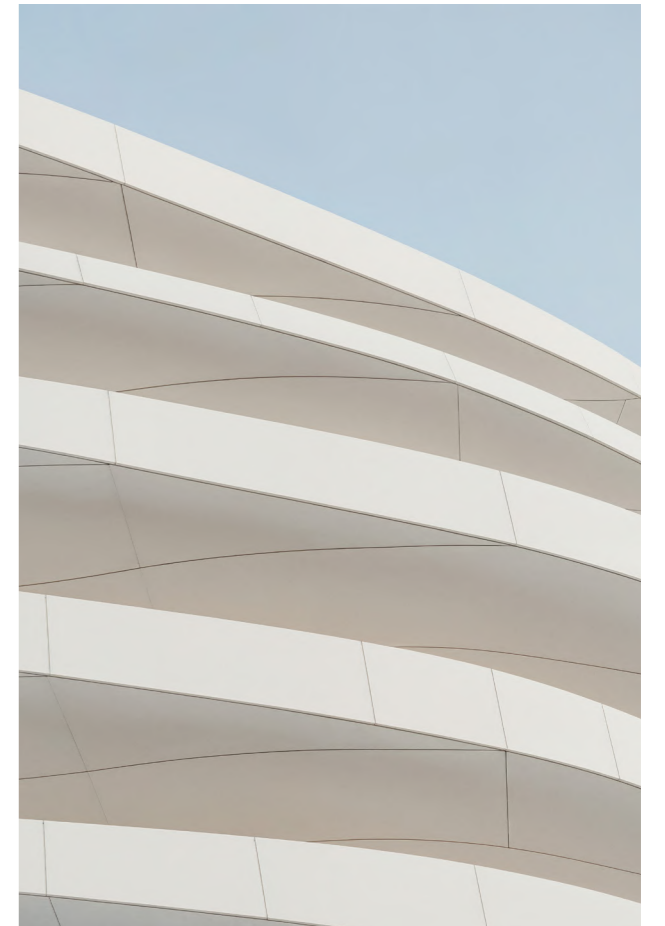



MPROJECT

contact@m-project.es

Barcelona - Spain